

Awaiting authorisation from Ofgem

Advanced Electricity Networks Limited

Statement of Methodology and Charges for Electricity Connections

Electricity Distribution Licence: Standard Licence Conditions
13 and 14



MAIN AUTHOR	APPROVER
David Hearn	Andrew Blincow
	
Head of Design	Managing Director
1 st December 2023	1 st December 2023
Document Number	AEN-RDS-003
Current Version	V1

REVISION HISTORY

Version	Date	Description
V1	1 st December 2023	Initial Publication

Important Note

This document comprises the Connection Charging Methodology and the Connection Charging Statement of **Advanced Electricity Networks Limited**.

The Connection Charging Methodology describes the methodology that Advanced Electricity Networks Limited will use to determine the charges for making a connection to their electricity distribution systems. The Connection Charging Statement sets out the basis on which charges will be made for the provision of connections to Advanced Electricity Networks Limited's distribution system.

This document has been prepared in accordance with the requirements of our Licence issued under the Electricity Act 1989 (as amended).

At our discretion, we may charge a fee of £10 (plus VAT) for each hard copy of this document provided in accordance with a request. An electronic copy of this document is available free of charge from the AEN website at:

www.advancedelectricitynetworks.co.uk

CONTENTS:-

1	General information	6
	Competition in Connections	6
	Contractual Framework	7
	Offer to Connect Premises and to Construct the Connection (Connection Offer)	7
	Offer to undertake Non-Contestable Work only (Point of Connection Offer)	7
	Adoption Agreement	7
	Connection Agreement	8
	Appointment of a Supplier	8
	Structure of this Document and Further Information	9
	Disputes/Complaints	10
2	Applying for a connection to our Distribution System	10
	Persons Entitled to Apply for a Connection	11
	Procedure for getting a connection.	11
	Information We Require from You	12
	Budget Estimates	13
	Feasibility Studies	14
	Cost Breakdown	14
	Interactive Connection Applications	15
	Transitional Arrangements	15
	Connection Applications Process	15
	Application Process where AEN completes all the works.	16
	Application Process when an ICP carries out the Contestable Works, but you still wish us to adopt the Contestable Work	17
	Standards of performance for Point of Connection Applications	19
	Small Scale Embedded Generation	20
	Embedded Networks	21
3	Further information on connection applications	21
	Connection Offer and Point of Connection Offer Validity Periods	21
	Contestable Work	22
	Non-Contestable Work	23
	Contestable Reinforcement and Diversionary Work	24
	Increase or Decrease in Required Capacity	25
	Temporary De-energisation	25
	Capacity of Domestic Connections	25
	Large Low Voltage Connections	25
	Available Capacity	26
	Helpful Advice for Reducing Your Connection Charge	26
4	Connection Charging Methodology	27
	Introduction	27
	Payment Terms	27
	Minimum Scheme	27

Enhanced Scheme	28
Costs.....	28
Cost Allocation	29
Costs to be paid in full by you.....	29
Costs of Reinforcement.....	32
Costs to be apportioned between you and us.....	34
Recovery of costs for previous works	36
Costs to be paid in full by us.....	36
Additional Cost Allocation for Flexible Connections and Curtailable Connections.....	39
Recovered Equipment and Deferral of Asset Replacement	40
Rebates	41
Speculative Developments.....	41
Criterion 1: Programme (domestic and non-domestic developments)	43
Criterion 2: Programme (domestic developments only)	43
Criterion 3: Load Profile	43
Criterion 4: Financial Commitment.....	44
Criterion 5: Future Provision	44
Criterion 6: Planning Permission.....	44
Connection Alterations	44
Capacity Ramping for LDNOs	44
Competition in Connection Charges	45
Land Rights.....	45
Unmetered Supplies	45
Disconnection	46
Phased Capacity Site	46
5 Worked examples illustrating the application of the connection charging methodology.....	48
Key to Illustrations	49
6 Our specific connection charging methodology	107
Capitalised Operation and Maintenance Charges	107
Projects	107
Non-Standard Substation Buildings	107
Charges for assessment and design	107
Reservation of Import Capacity	107
Contestable and Non-Contestable works	108
7 Our connection charging statement.....	109
Introduction	109
Quotation Accuracy Scheme	111
PART A - Budget Estimates.....	113
PART B - Feasibility Studies	114
PART C - Assessment and Design for all relevant work.....	117
PART D - CIC Assessment and Design of the Non-Contestable Work	119
PART E - CIC Design Approval of the Contestable Work	120
PART F - CONSTRUCTION	122

PART G CIC Final Works and Energisation.....	136
PART H CIC Inspections and Monitoring of Contestable Works	137
PART I - Land Rights	138
PART J Other	138
8 Glossary of terms.....	139

1 General information

- 1.1 Advanced Electricity Networks Limited (AEN) is a licensed independent distribution network operator which owns and operate electricity distribution networks throughout Great Britain. Typically, our electricity networks connect to the distribution systems of licensed distribution network operators operating within their defined distribution Services area.
- 1.2 The provision of a connection to AEN's Distribution System may be undertaken by us, or by one of our agents. Alternatively, certain connection activities may be undertaken by an Independent Connections Provider (ICP) which you may appoint.
- 1.3 This document describes the Connection Charging Methodology that we will apply in determining the charges we will make where we provide connections to AEN's Distribution System and provides details of illustrative costs. The document also describes how you can obtain a new or altered connection to AEN's Distribution System.
- 1.4 We will review this document at least once a year to ensure that the information continues to be accurate in all respects. Any changes we make to this document will be made in accordance with our licence obligations. Costs shown in the Connection Charging Statement are current at the time of publication and are subject to change without notice except as otherwise provided.
- 1.5 Certain words in this document are capitalised, e.g., Distribution System. These words have a specific meaning which is set out in the Glossary of Terms (Section 8). The words "you," "your" and "yourself" refer to the Customer, the person requesting a connection, their company or agent and "we," "us," "our" and "ourselves" refer to AEN.

Competition in Connections

- 1.6 You may choose to have some of the connections' work (described as Contestable Work) carried out by an Independent Connections Provider (ICP). The elements of work that an ICP may undertake include the design, procurement, and installation of new assets necessary to provide the electricity connection.
- 1.7 Section 3 of this document contains details of the elements of work which are Contestable and Non-Contestable, and the arrangements that will apply if you choose to appoint an ICP to carry out Contestable Work.
- 1.8 Non-Contestable Work can only be carried out by us or by our appointed agents.
- 1.9 If you wish to appoint an ICP to carry out Contestable Work, and for us to adopt the Contestable Work after they are completed, you and/or your ICP must enter into an Adoption Agreement with AEN before your ICP commences any of the Contestable Works. Contestable Works undertaken by an ICP and subsequently adopted by AEN pursuant to an Adoption Agreement are outside the scope of this document. The design, construction and commissioning of contestable work must comply with AEN's G81 standards.
- 1.10 Unless we agree otherwise in writing, where you choose to appoint an ICP to undertake Contestable Works, the ICP must be accredited through the Lloyds NERS Register.

1.11 Further information describing the process and options available is provided in Section 2 of this document.

Contractual Framework

1.12 Depending on the size and type of the connection and whether you wish us or an ICP to undertake any Contestable Work you will need to enter into a set of contractual arrangements with us. Unless you are another licensed distributor, you will also need to appoint a Supplier who must also be a party to various industry agreements and codes.

Offer to Connect Premises and to Construct the Connection (Connection Offer)

1.13 A Connection Offer is the offer that we make to you where you have asked us to carry out the connection works (both Non-Contestable and Contestable Work) which will, if accepted by you, create a legally binding contract between you and us. The terms of the Connection Offer will depend, amongst other things, on the complexity and value of the work to be carried out.

Offer to undertake Non-Contestable Work only (Point of Connection Offer)

1.14 A Point of Connection Offer is the offer that we make to you where you have asked us to carry out the Non-Contestable Work to provide a Point of Connection to our Distribution System that the Contestable Work provided by an ICP can connect to. The terms of the Point of Connection Offer, if accepted by you, will create a legally binding contract between you and us. The terms will depend, amongst other things, on the complexity and value of the work to be carried out.

Adoption Agreement

1.15 As set out in Paragraph 1.9 above, if an ICP is to undertake Contestable Works and you want us to adopt the Contestable Works after they have been completed an Adoption Agreement must be completed prior to the commencement of Contestable Works. The agreement will set out the terms under which we will take ownership of, and responsibility for, the assets provided in the Contestable Works. The agreement will include, among other things:

- the transfer of title from the asset owner (normally the Customer or the ICP) to us.
- the quality and safety requirements of the asset to be adopted.
- any required sureties.
- the transfer of Land Rights.
- the procedure for us to energise the assets installed by the ICP during the works.
- the payment of any residual Connection Charges or fees.
- planning permissions and compliance with street works legislation; and,

- defect correction processes, where applicable.

The parties to the Adoption Agreement may vary depending on the circumstances and the Adoption Agreement may be between:

- us and you.
- us and your appointed ICP; or
- us, you and your appointed ICP.

Connection Agreement

1.16 The owner/occupier of the Premises to which the connection is to be provided or the IDNO or the Licence Exempt System operator will be required to enter into a Connection Agreement with us. The Connection Agreement will set out the terms upon which the premises can be, and remain, connected to our Distribution System. The Connection Agreement will normally be provided on our behalf by the owner/occupier's chosen Supplier for the Premises as part of their application for a supply of electricity.

1.17 For most sites, the Connection Agreement will comprise the National Terms of Connection put in place on our behalf by your appointed Supplier. In some circumstances we may require you to enter into a separate Connection Agreement covering the specific connection characteristics of your site.

This will only take effect upon completion of the connection and will set out, in more detail, the respective rights and obligations of us and of the owner/ occupier. Additionally, the Connection Agreement may contain technical details of the installation being connected to the Distribution System and will require the owner/occupier of the Premises to comply the provisions of the Distribution Code.

1.18 The Distribution Code covers, amongst other matters, all material technical aspects relating to:

- connection to, and the operation and use of a IDNO's Distribution System; and
- the operation of electrical lines and electrical plant or apparatus connected to a IDNO's Distribution System.

A copy of the Distribution Code can be downloaded from the Distribution Code website at www.dcode.org.uk.

Appointment of a Supplier

1.19 In order to receive a supply of electricity you must appoint and enter into an agreement with a Supplier. Unless we agree that your connection qualifies to be treated as an Unmetered Supply, your Supplier must also arrange for the installation of metering equipment appropriate for the connection that is being provided for you. Alternatively, you may agree with your supplier arrangements where you install the metering equipment. Where it is required, the metering equipment must be installed before a supply of electricity can be provided to a Premises.

1.20 In order to obtain a supply of electricity, you will need a Supply Number (also known as a Meter Point Administration Number or 'MPAN') for each connection. We will issue the MPAN shortly before installing the connection, but only upon receipt of the full postal address of the Premises.

Please note that we are unable to give advice on a choice of Supplier.

The Citizens Advice Bureau website maintains a list of Suppliers, see their website for further details: www.citizensadvice.org.uk.

1.21 Energisation of the connection to your Premises will not take place unless a Supply Number has been allocated, a Supplier has been appointed and the appropriate metering equipment, where this is required, has been installed and commissioned.

1.22 Your Supplier will be a party to a number of industry codes and agreements which, will allow it to use the GB Transmission System, our Distribution System and also allow it to purchase and trade energy on behalf of its customers.

Structure of this Document and Further Information

1.23 The document is divided into a number of Sections.

1.24 Section 2 outlines the high-level process for applying for a connection to our Distribution System when either we, or an appropriately accredited ICP, carry out the Contestable Works.

1.25 Section 3 provides further information specific to us regarding obtaining a connection.

1.26 Section 4 describes the elements of the Connection Charging Methodology that have analogous paragraphs in the Common Connection Charging Methodology which we will use to calculate Connection Charges.

1.27 Section 5 contains worked examples of the Connection Charging Methodology and how it would be applied in particular circumstances.

1.28 Section 6 contains the parts of our specific Connection Charging Methodology which do not have a counterpart paragraph in the Common Connection Charging methodology but will equally be used in calculating your Connection Charges

1.29 Section 7 contains the Connection Charging Statement which, when used in conjunction with Section 4, enables reasonable estimates of the charges liable for connection to be made.

1.30 Section 8 provides a glossary of terms used throughout the document.

For further information about this document (or if you need advice about getting a connection), please contact:

- by writing to the following address:

FAO Connections Administrator
Advanced Electrical Networks Limited
Nexus Park
Avenue East
Skyline 120

Great Notley
Braintree
Essex
CM77 7AL

- or by telephone to Advanced Electrical Networks Limited General Enquiries on **01376 332 689**
- or by email to enquiries@advancedelectricitynetworks.co.uk.

Disputes/Complaints

- 1.31 If you are not satisfied with the terms we have offered, or with our handling of your application, please use the contact details in section 1.30 above, marking the communication as a complaint.
- 1.32 If you are still not satisfied with our actions and you have followed our complaints procedure, then domestic and small business customers have the right to contact the Energy Ombudsman. This is a free and independent dispute resolution service. They can be contacted at:

Ombudsman Services: Energy
PO Box 966
Warrington
WA4 9DF
Phone: 0330 440 1624
Fax: 0330 440 1625
Textphone: 0330 440 1600
Email: www.ombudsman-services.org/energy

- 1.33 If the Energy Ombudsman is unable to deal with or resolve the dispute then either party may request a determination of the matter by the Gas and Electricity Markets Authority (the Authority), whose details are:

The Office of Gas and Electricity Markets (Ofgem)
10 S Colonnade
Canary Wharf
London E14 4PU
United Kingdom

Email: www.ofgem.gov.uk

2 Applying for a connection to our Distribution System

This section sets out the process for applying for a connection to our Distribution System. As explained in paragraphs 1.6 – 1.10 you can appoint an ICP to carry out the Contestable Works relating to the provision of your connection. The principles and processes contained in this section are relevant to all connections to our Distribution System.

Persons Entitled to Apply for a Connection

- 2.1 Any person may apply in their own right for a connection to our Distribution System.
- 2.2 Any person may appoint an agent to apply for a connection on their behalf, but the agent may be required to provide written evidence of their appointment as an agent on application.
- 2.3 Persons entitled to seek connection to our Distribution System for the purpose of generating, supplying, or distributing electricity are those who are authorised by licence or by exemption under the Act to generate, supply or distribute electricity.

Procedure for getting a connection.

- 2.4 A person seeking a new or modified connection should contact us as detailed below:

General queries and POC application:

Advanced Electrical Networks Limited
Nexus Park
Avenue East
Skyline 120
Great Notley
Braintree
Essex
CM77 7AL
enquiries@advancedelectricitynetworks.co.uk

For single domestic connections, or alterations to existing connections:

Advanced Electrical Networks Limited
Nexus Park
Avenue East
Skyline 120
Great Notley
Braintree
Essex
CM77 7AL
enquiries@advancedelectricitynetworks.co.uk

- 2.5 Once we have received your completed application, we will process your request and provide you with a Connection Offer as soon as reasonably practicable. This will (subject to us receiving any information we may require when preparing the offer from the distributor to whose Distribution System our network connects) be no longer than three months.

The connection offer will specify the proposed Point of Connection to our Distribution System; the location of the Entry/Exit Point to the Premises or Distribution System to be connected; details of the work to be carried out by us; and the terms under which we will provide the connection. The link below will take you to our website where further information is available:

www.advancedelectricitynetworks.co.uk

Information We Require from You

- 2.6 When you make your application to us you will need to provide us with details about your requirements. The information we require as a minimum is set out below. Sometimes we may require additional information. If this is the case, we will contact you.
- 2.7 The information we require will vary depending on the nature of your connection request. Typically, we require the following details as a minimum in the completed application form:

- Your name and correspondence address and other (if any) contact details.
- The Premises address where the connection is required.
- Whether you require a Budget Estimate or a formal Connection Offer. A formal Connection Offer is a contractual document and more appropriate once you are in a position to decide whether the project can proceed to the construction phase.
- A site location plan showing the site boundary and proposed meter locations.
- The Required Capacity (your maximum power requirement).
- The date by which you require the connection to be made.
- Whether the connection is required for a fixed period or indefinitely.
- The type of connection(s) required, e.g., demand, generator or for a licensed embedded network.
- Any information you have in respect of equipment you may install and which may interfere with our Distribution System or the supply of Electricity to others (e.g. apparatus which can cause voltage fluctuations, such as large motors associated with air conditioning system, lifts, cranes, hoists and other similar plant; or apparatus which can produce harmonics, such as uninterruptible power supplies or electronic control systems).

Further information that we may typically require from you if you intend for us to undertake all the works will be:

- A site layout plan, drawn to a suitable scale, indicating where the connection(s) are required.
- The number of connections you require.
- The required capacity for each connection.
- Whether the connection is required for a fixed period or indefinitely.

An application form can be obtained by emailing:

enquiries@advancedelectricitynetworks.co.uk

2.8 If you do not provide us with the information we need, it may prevent us from dealing with your enquiry quickly; so please provide the information indicated on our application form.

Budget Estimates

2.9 If you make an enquiry that is of a provisional nature, we will provide a Budget Estimate to give you an indication of what we believe the charge for providing the connection may be. In providing this estimate we will only carry out a desk top exercise using broad base assumptions to assess the likely works we will need to undertake; we will not carry

out any detailed analysis specific to the site. Therefore, you should note that the estimate we provide at this stage may vary considerably from any further Budget Estimates or the price in any formal Connection Offer. A Budget Estimate is not a formal offer for connection and cannot be accepted by you. See Section 7, Part A for charges associated with the provision of Budget Estimates.

Feasibility Studies

2.10 At your request we will undertake a Feasibility Study to consider a number of options for connection and provide estimated costs for each option as appropriate. Generally, this will be for more complex connections. A Feasibility Study is not a formal offer for connection and cannot be accepted by you. Any estimated cost in such study will be purely indicative and not binding. The price in any subsequent Connection Offer to you may differ from it. See Section 7, Part B for charges associated with the provision of Feasibility Studies.

Cost Breakdown

2.11 Where we make a Connection Offer for providing a connection to our Distribution System, we will provide you with a breakdown of our charges so that they can be referenced to the tables in Section 7. As a minimum this breakdown will include:

- a description of the works we will undertake, including whether it is an Enhanced Scheme.
- the length of underground cable required.
- information of any reinforcement works that are required; and
- legal and professional charges associated with the securing of Land Rights.

2.12 Our Connection Offer to you will normally be based on the Minimum Scheme required to provide the connection. Sometimes we may undertake works that are in addition to those required by the Minimum Scheme (i.e., an Enhanced Scheme). This may be:

- where we propose to undertake works that are over and above those required by the Minimum Scheme; or,
- where you require us to undertake additional works, (for example, to provide enhanced system security).

Where the additional works in the Enhanced Scheme are at our request the Connection Charge to you will be based on the Minimum Scheme. We will provide you with a breakdown of the costs for both the Minimum Scheme and the Enhanced Scheme. Where the Enhanced Scheme comprises of additional works requested by you the Connection Charge to you will be based on the Enhanced Scheme and we will provide you with a cost breakdown for the Enhanced Scheme.

Interactive Connection Applications

- 2.13 We may receive connection applications from more than one party for connections to the same part of the Distribution System, and whilst each connection application could be accommodated on an individual basis, there may be insufficient spare capacity or other network constraints to accommodate more than one of the connection applications. Where we receive multiple applications for connection to the same part of our Distribution System, we will apply an Interactive Connection Application process in order to prioritise connection applications fairly. We will apply this process for all applications for connection to our Distribution System where the requested Maximum Capacity (the maximum power requirement) is stated as being in excess of 1MVA.
- 2.14 The Application Date (please refer to the Connection Process section below) will be used to sequence Connection Offers in time order such that the first Connection Offer will be made to the first applicant to reach the 'application' stage of the process, and so on. All parties will be notified in writing if their application is Interactive or becomes Interactive with others. Where a current Connection Offer is open for acceptance, the Validity Period set out in the terms of such Connection Offer will be reduced to thirty (30) days from the date of any such notification, where more than thirty (30) days are still outstanding.

Transitional Arrangements

- 2.15 The Connection Charge quoted in a Connection Offer will be calculated in accordance with our Connection Charging Methodology that is current at the time the offer is provided. If you accept our Connection Offer, and the connection works are carried out within the prescribed time set out in it, the Connection Charge will be the charge that shall apply even if there is a subsequent change to our Connection Charging Methodology.

Connection Applications Process

- 2.16 The flow chart below illustrates how your application for a connection to our Distribution System will be processed, dependent on whether we carry out all the works or you appoint an ICP to carry out the Contestable Works. Further information explaining each stage of the process is available in paragraphs 2.16 to 2.30.

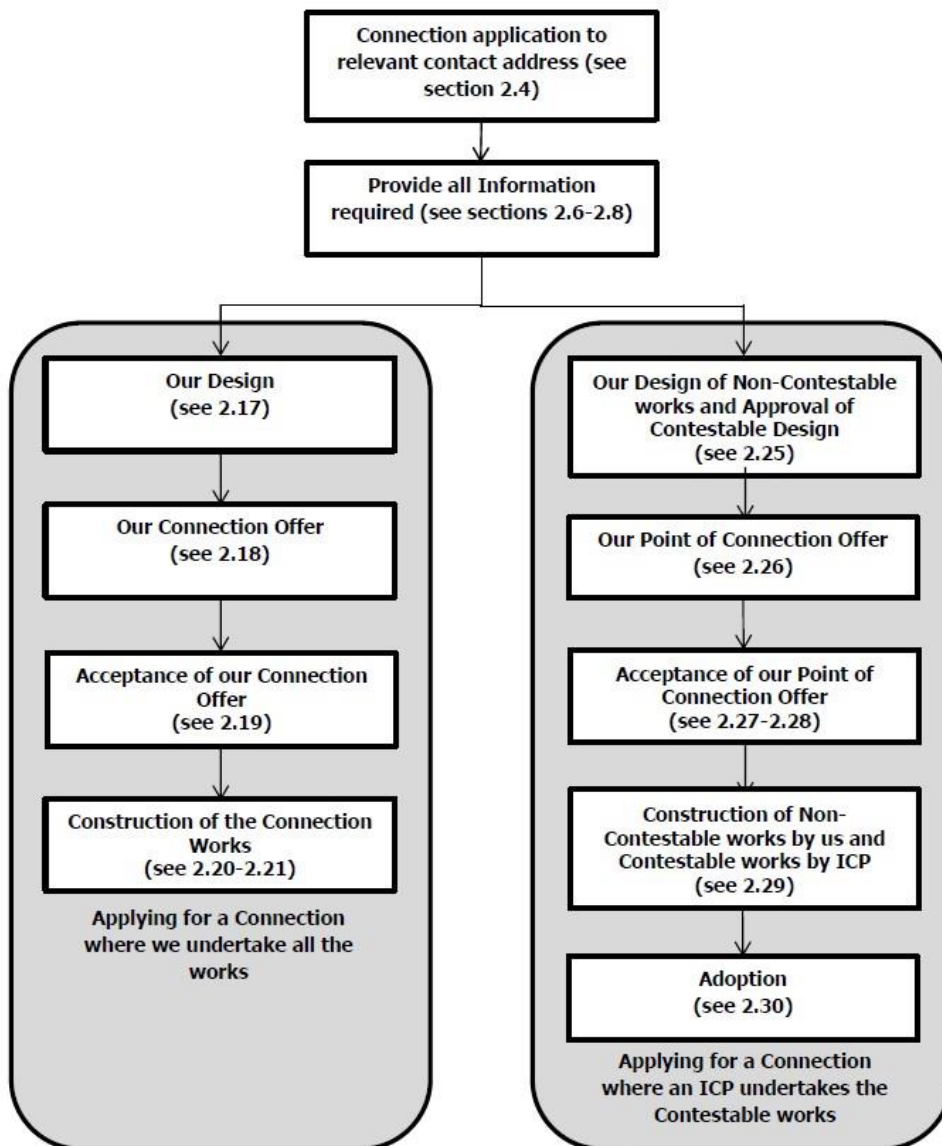

The Connections Application Process

Application Process where AEN completes all the works.

You do not need to request a Budget Estimate before you request a Connection Offer. When you request a connection to our Distribution System, we will deal with your request using the following process.

Stage 1 – Making Your Application

- 2.17 When you make your connection application it is important that you provide all the information listed in paragraph 2.7 so that we can process your enquiry. Occasionally we may require additional information before we can process your enquiry. We will notify you where this is the case.

Stage 2 – Our Design

- 2.18 We will design the connection for you, taking into account the location of the Premises for which the connection is required, its proximity to the existing Distribution System and the available capacity in the Distribution System to provide the connection that you require. Additionally, our design will specify any reinforcement that is required on our existing Distribution System (or on the distribution system to which our Distribution System connects) in order to accommodate your connection.

Stage 3 – Our Connection Offer

- 2.19 When we have completed the design, we will make a Connection Offer to you. This will set out the work we will need to undertake to provide a connection between your premises and our Distribution System. Also, the Connection Offer will set out our Connection Charge and the terms and conditions for making the connection. The price in the Connection Offer may vary considerably from any previous Budget Estimate or Connection Offer. The Connection Offer will set out how long it is open for your acceptance (the Validity Period). The Validity Period will be subject to the Connection Offer not becoming an Interactive Connections Offer as described in paragraph 2.13 above.

Stage 4 – Acceptance of our Connection Offer

- 2.20 If you wish to accept our Connection Offer to the Distribution System you must:
- accept that offer in accordance with its terms within the Validity Period; and
 - make any required payment in accordance with the requirements in our Connection Offer.

Stage 5 – Construction of the Connection Works

- 2.21 We will carry out the construction work to provide the new connection in accordance with the provisions to the terms of the Connection Offer you have accepted. We will liaise with you during the planning and execution of the works.
- 2.22 Supply Numbers (Metering Point Administration Numbers or 'MPANs') will be issued before the connection works are completed, so that you can make arrangements with your Supplier for the supply of electricity to the Premises. On completion of this stage, the work required to provide the connection will have been undertaken and will be available for your Supplier to arrange for the installation of metering equipment, or where agreed with us, for use as an Unmetered Supply.

Application Process when an ICP carries out the Contestable Works, but you still wish us to adopt the Contestable Work

- 2.23 You may appoint an ICP to undertake some or all of the Contestable Work. You can ask us to adopt the Contestable Work or may choose to have the Contestable work adopted by someone else. If you decide to have the Contestable Work adopted by someone else, this will constitute an Embedded Network requiring a Bilateral Connection Agreement as discussed in paragraphs 2.35 to 2.37 below. If, however,

you wish to appoint us to adopt Contestable Work constructed by an ICP, the ICP may make an application on your behalf and your request for a Point of Connection Offer will be processed in the following way:

Stage 1 – Your Application

- 2.24 We will only be able to progress your connection application once you have provided us with the information we require (see 2.7). We will notify you within five Working Days if we require any additional information in order to process your application.
- 2.25 If you choose to appoint an ICP to carry out the Contestable Work then the Point of Connection will be determined by us based on the information provided to us by the ICP and taking into account the ICP's requirements and our wider obligations. For larger demand and generator connections more than one Point of Connection may need to be assessed. A table showing our indicative charges for assessing the Point of Connection is given in paragraph 7.17. These charges will be included within the Point of Connection Offer. If you wish to undertake assessment of the Point of Connection, then we will provide you with all the necessary information in order for your ICP to undertake the assessment. Your ICP will need to be suitably accredited in order to undertake this assessment.

Stage 2 – Our Design

- 2.26 Our design of the Non-Contestable Work and the identification of the Point of Connection will take into account the location of the Premises for which a connection is required, its proximity to our Distribution System, and the available capacity in our Distribution System to provide the connection you require. Additionally, our design will specify any reinforcement that is required on our existing Distribution System and/or on the Distribution System to which our Distribution System connects in order to accommodate your connection.

Stage 3 – Our Point of Connection Offer and the Adoption Agreement

- 2.27 This is our formal written offer to you to provide the connection to our Distribution System. The Point of Connection Offer will set out the terms and the price upon which we will make that connection, whilst the Adoption Agreement will set out the terms under which we will adopt assets installed by your ICP. The Point of Connection Offer that we make to you may be accepted by you in accordance with its terms at any time within the Validity Period set out in our Point of Connection Offer. The price in our Point of Connection Offer may be different from any previous Budget Estimates.

Stage 4 – Acceptance of our Point of Connection Offer

- 2.28 If you wish to accept our Point of Connection Offer, you must:
- accept the Point of Connection Offer in accordance with its terms within the Validity Period.
 - obtain design approval from us for the Contestable Work in the timescales specified.
 - make any required payment by the date and means specified in our Point of Connection Offer; and

- return the signed Adoption Agreement in the timescale specified.

2.29 A valid acceptance of our Point of Connection Offer will create a legally binding agreement between us. Where the terms of the Adoption Agreement have been unaltered, we will sign the Adoption Agreement and return a copy to the relevant parties.

Stage 5 – Construction by us and the ICP

2.30 At this stage we will carry out construction of the Non-Contestable Works and the ICP will carry out construction of the Contestable Works. We may carry out routine inspections of the Contestable Works as it is installed. Such inspections will be on the same basis as those we carry out in respect of our own connections work. Shortly before the Contestable Works is ready for connection to our Distribution System your ICP must contact us so that we can arrange a date for connection. Subject to the provision of any required documentation and the satisfactory completion of any required tests we will connect the Contestable Works to our Distribution System and, where agreed, adopt the assets. Supply Numbers (Metering Point Administration Numbers or ‘MPANs’) will be issued before the Connection Works are completed, so that arrangements can be made with your Supplier. On completion of this stage, the Extension Assets and Entry/ Exit Point(s), as appropriate, will have been commissioned and will be available for meters to be installed or, in the case of Unmetered Supplies, be ready for use.

Stage 6 – Adoption of the Contestable Works by us

2.31 Adoption will be in accordance with provisions of the Adoption Agreement described in paragraph 1.14.

Standards of performance for Point of Connection Applications

2.32 Appendix 1 of Standard Licence Condition 15 of our Distribution Licence sets out the standards of performance that we must take all reasonable steps to comply with when providing Point of Connection Offers, design approval, connection, and Energisation of the connection. These standards apply where you have provided us with the necessary information, we need to undertake the work and, where relevant we receive the required information from the relevant distributor (to whose distribution system our Distribution System connects). These standards are set out in the table below:

Provision of Point of Connection Offers	Performance
(a) Low voltage demand: for a new demand connection to our Distribution System where the highest voltage of the assets at the Point of Connection and any associated works is not more than one kilovolt.	Within fifteen Working Days of receiving the request.

<p>(b) Low voltage generation: for a new generation connection to our Distribution System where the highest voltage of the assets at the Point of Connection and any associated works is not more than one kilovolt.</p>	<p>Within thirty Working Days of receiving the request</p>
<p>(c) High voltage demand: for a new demand connection to our Distribution System where the highest voltage of the assets at the Point of Connection and any associated works is more than one kilovolt but not more than 22 kilovolts.</p>	<p>Within twenty Working Days of receiving the request</p>
<p>(d) High voltage generation: for a new generation connection to our Distribution System where the highest voltage of the assets at the Point of Connection and any associated works is more than one kilovolt but not more than 22 kilovolts.</p>	<p>Within fifty Working Days of receiving the request</p>
<p>(e) Extra high voltage demand: for a new demand connection to our Distribution System where the highest voltage of the assets at the Point of Connection and associated works is more than 22 kilovolts but not more than 72 kilovolts.</p>	<p>Within fifty Working Days of receiving the request</p>
<p>(f) Other connections: for a new demand connection or generation connection to our Distribution System that is not included within the preceding subparagraphs.</p>	<p>Within sixty-five Working Days of receiving the request</p>

Further information on these standards of performance can be found on our website at: www.advancedelectricitynetworks.co.uk

Small Scale Embedded Generation

2.33 Small Scale Embedded Generation (SSEG) is defined as a source of electrical energy with a rating up to and including 16 Amperes per phase, single or multi-phase LV, and designed to operate in parallel with our Distribution System. If you install a SSEG unit (typically domestic combined heat and power units, domestic photovoltaic and domestic wind turbines), you must, in accordance with statutory requirements, advise us of your intention to utilise the SSEG installation no later than 28 days (inclusive of the day of commissioning), after its commissioning.

2.34 Engineering Recommendation G83/1-1 entitled “Recommendations for the Connection of Small-Scale Embedded Generators (Up to 16A per phase) in Parallel with Public Low-Voltage Distribution Networks” is published by the Energy Networks Association (ENA). It sets out the technical requirements for the connection of SSEG units. For further information visit the ENA website. (www.energynetworks.org)

2.35 For the connection of other types of generators please follow the process above so we can make an offer to connect your generator. Further information can be found in our Distributed Generation Connections Guide which can be accessed from our website.

Embedded Networks

2.36 Any person wishing to build a distribution network requiring a connection to our Distribution System should apply to us using the processes set out in this Section.

2.37 We accept and shall work to Engineering Recommendation G88 entitled; “Principles for the planning, connection and operation of electricity distribution networks at the interface between Distribution Network Operators (DNOs) and Independent Distribution Network Operators (IDNOs)”, published by the ENA.

2.38 A Bilateral Connection Agreement will be required between us and the connected party, setting down the specific terms and conditions that will govern the connection of the distribution network to our Distribution System once the connection works are completed. While such terms and conditions will be consistent with our Connection Charging Methodology, the Bilateral Connection Agreement will take precedence.

3 Further information on connection applications

3.1 This section sets out further information with regards to obtaining a connection to our Distribution System.

Connection Offer and Point of Connection Offer Validity Periods

3.2 Any Connection Offer given will normally be open for acceptance for ninety days from the date on the letter. This is the Validity Period. After that period, the Connection Offer will expire and will no longer be open for acceptance. The Connection Offer is also provided on the understanding that the connection works are started and completed within a determined period of time. This period will vary depending on the type and complexity of the connection works required. If, following acceptance of the Connection Offer, the connection works are not:

- completed within the determined period of time,
- progressed in accordance with agreed milestones and such failure to complete or progress the connection works is due to any act of default or omission by you or your agents, we reserve the right to withdraw the Connection/Point of Connection Offer and make a new Connection/Point of Connection Offer under such terms and conditions as are appropriate at the time.

and such failure to complete or progress the connection works is due to any act of default or omission by you or your agents, we reserve the right to withdraw the Connection/Point of Connection Offer and make a new Connection/Point of Connection Offer under such terms and conditions as are appropriate at the time.

Contestable Work

3.3 We consider the following work to be Contestable with regards to our Distribution System and as such the work may be carried out in its entirety by a suitably accredited ICP:

- assessment of a point of connection
- design of the Contestable Work.
- the procurement and provision of equipment and materials to our current specification for the Contestable Work.
- trenching and other preparation of the site, including the circuit routes between the development and the Point of Connection.
- construction of the Contestable Work.
- determining the Point of Connection to our Distribution System at LV and HV unless expressly considered non-contestable.
- connection of Contestable Works to the Distribution System and their Energisation at LV and HV only.
- recording of work done and of the location of cable routes and other equipment on site or elsewhere (where those assets are installed by the ICP), and the provision of this information to us. Provision and installation of HV switchgear, including any plant or equipment required for the automation of our networks, in accordance with our technical specifications.
- reinstatement (both temporary, if appropriate, and permanent).
- making provision for the installation of metering equipment.
- Land Rights negotiations to our standard terms.

Under certain circumstances and at our sole discretion, we may agree that you undertake part of the Contestable Works whilst we carry out the remainder where it is practical to do so.

3.4 The Contestable design element must comply with the appropriate parts of Engineering Recommendation G81 and any of our specific requirements (our appendices to Engineering Recommendation G81). Following receipt of the design of the Contestable Work we shall either provide written confirmation of approval or explanation for rejection. Such approval shall not be unreasonably withheld. A charge will not be made for approval of any design work undertaken by an ICP. Where the Contestable design has been undertaken by a suitably accredited ICP whom we have granted “self-approval” status, we shall not be required to approve the design.

3.5 We may, on occasion, request the ICP to include additional features in the design. Such requests shall be made in writing and as soon as is reasonably practicable. Where the ICP accepts this request, we will meet the agreed reasonable additional cost.

3.6 Specification for design, materials, installation, and recording, is governed by Engineering Recommendation G81, a seven-part national framework document

administered by the Energy Networks Association that is designed to be supplemented by our specific appendices. Any ICP carrying out such Contestable Work must comply with the specification. The seven parts comprise: For green field and brown field housing estates:

- **Part 1:** Framework for Design and Planning
- **Part 2:** Framework for Materials Specification
- **Part 3:** Framework for Installation and Records

For industrial and commercial connections:

- **Part 4:** Framework for Design and Planning
- **Part 5:** Framework for Materials Specification
- **Part 6:** Framework for Installation and Records

All of the above must be read in conjunction with our corresponding suite of appendices that supplement Engineering Recommendation G81.

For diversionary and Reinforcement works:

- **Part 7:** Framework for contestable diversionary and Reinforcement underground and overhead works not exceeding 33kV and HV/LV distribution substations.

These documents are available to view on the ENA website at:

<http://www.energynetworks.org/>

A copy of our supplementary documents can be requested from:

enquiries@advancedelectricitynetworks.co.uk

Non-Contestable Work

3.7 We consider that the following works in respect of our Distribution System are deemed to be non-Contestable and, as such, can only be carried out by us or our appointed agents:

- Processing your application and Distribution System planning for the connection.
- Deciding upon the Point of Connection to the Distribution System in exceptional circumstances as may be published from time to time.
- Connection of the Contestable Work to the Distribution System other than at LV or HV.
- Design, planning and specification of any works for Reinforcement of our Distribution System.
- Carrying out of any works for Reinforcement of our Distribution System where the conditions for such work being Contestable Work are not met.

Reinforcement (other than design and specification) and diversionary works may be contested when associated with the provision of a connection and subject to the circumstances in paragraph 3.9.

- Design, planning and specification of any works for the diversion of the Distribution System, where the conditions for such activity being Contestable Work are not met (the design of diversionary works may be Contestable when associated with the provision of a connection and subject to the circumstances described in paragraph 3.9.
- Removal and/ or the diversion of existing Electrical Plant and Electric Lines when they are not related to contestable works.

3.8 The following works in respect of Contestable Works are deemed to be non-Contestable:

- Specification of the design and installation criteria and materials to be used for Contestable Works.
- Concluding any Land Rights and consents that we require.
- Approval of the ICP's design where the ICP does not have the necessary accreditation or does not wish to self-approve the design.
- Operational activity associated with the connection of Extension Assets or diverted assets to the Distribution System.
- Operation, repair and maintenance of the Electrical Plant and the Electric Lines following adoption by us (for the avoidance of doubt, this does not detract from the ICP's obligations to repair defects within the warranty period set out in the Adoption Agreement).
- Inspection, monitoring, and testing of any contestable work.

Contestable Reinforcement and Diversionary Work

3.9 Certain types of Reinforcement and diversionary work on our Distribution System may also be carried out by suitably accredited ICPs for adoption by us. The scope of such work is limited to Reinforcement and diversionary works, associated with a connection, which:

- are new works that are physically and electrically separate from our existing Distribution System.
- do not require access to our existing operational areas.
- are fully funded by the single third party who is seeking the connection; and
- are restricted to works to install underground cables at voltage levels not exceeding 33kV and works to install HV/LV distribution substations.

In the circumstances above a suitably accredited ICP may also carry out the connection of diverted assets to the Distribution System and their Energisation where the connection is made at LV or HV by live jointing to an underground cable section of the Distribution System (in areas where the LV Distribution System is operated on an

interconnected basis we will need to carry out operational activity before the live jointing may commence).

- 3.10 The design of Reinforcement works can require a large volume of information that would need to be made available to allow the ICP to carry out such design works which is likely to outweigh the benefits of including design work within the scope of contestability. The design of connection Reinforcement therefore remains non-Contestable.
- 3.11 Where Reinforcement or diversionary work is required on the Distribution System of another IDNO/DNO then you or your ICP will be required to liaise directly with the relevant IDNO/DNO.

Increase or Decrease in Required Capacity

- 3.12 If you wish to increase or decrease the Required Capacity of an existing connection you can make a request by submitting an application to us at the address given in paragraph 2.4.
- 3.13 Any request to increase the Required Capacity will be considered by us and you will be informed whether the additional load is immediately acceptable or whether Reinforcement work must first be carried out. Any costs for reinforcing our Distribution System will be charged for in accordance with Section 4 of this document.
- 3.14 Any increase or decrease in Required Capacity shall normally be formally agreed by the implementation or variation of a Connection Agreement.
- 3.15 No decrease in Required Capacity for import shall take effect earlier than twelve months from the date of original connection, or twelve months from the last variation made to the Required Capacity.

Temporary De-energisation

- 3.16 An electrical installer may request we temporarily De-energise and subsequently Re-energise our Distribution System to enable that person to work on your own wiring and equipment safely. We typically require notice of at least 10 working days to provide this service and a charge may apply.

Capacity of Domestic Connections

- 3.17 All new domestic connections for non-electrically heated dwellings will have the ability to deliver a maximum demand capacity of 15kW, unless agreed otherwise with the applicant. (This does not imply that a generator with a rated output of 15kW can be accepted on that connection).

Large Low Voltage Connections

- 3.18 We will normally provide connections with a maximum residential demand capacity of up to 1000kVA at low voltage. However, we will take into account your particular requirements for a connection at high voltage and any disturbing loads (such as large motors or welding equipment) you wish to connect, together with the possibility of any future load increase in determining the voltage at which the connection is given.

Available Capacity

3.19 The capacity available on our existing Distribution System will be determined on the basis of capacity that is currently available and which is not currently covered under any existing Connection Agreement, Adoption Agreement or other commercial contract or agreement as may be considered to have reserved capacity.

Helpful Advice for Reducing Your Connection Charge

3.20 3.20 Your Connection Charge will, normally, be based on the estimated costs of the Minimum Scheme. However, we are happy to discuss with you regarding ways of reducing your connection charge. The list below identifies some of these, which you may wish to consider.

- If you can provide full details of your maximum power requirements when you make your application this will keep the time to a minimum in designing and producing a Connection Offer. Please remember that you have a legal obligation to provide all relevant information regarding your existing and/or proposed load details.
- Connection Offers are provided subject to the availability of any necessary legal consents, however, if you are able to provide assistance in these matters, this may help to reduce your connection charge. Legal consents may be easier to obtain if all the equipment required for your connection will be situated within your land.
- You may wish to consider carrying out the excavation works on your land, for instance the provision and installation of suitable ducts together with any road crossing ducts, as necessary.
- Accepting a service position as close to the distribution system as possible will result in the service cable length being kept to a minimum which in turn will reduce the amount charged by us.
- If a substation is required for your connection(s) you may wish to consider the following:
 - o Can the substation site/land be provided at no cost to us?
 - o Is the substation site to be provided in the optimum position? (This will be in agreement with us)
 - o Can you construct a substation base and building? (These will be in accordance with our specifications)
 - o Can you provide suitable routes for any cables across your property?

4 Connection Charging Methodology

Introduction

4.1 This section sets out the parts of our Connection Charging Methodology where there are analogous paragraphs contained within the Common Connection Charging Methodology. The parts of our methodology specific to us are contained in Section 6. Adherence to this section, and Section 6, will ensure a consistent approach in the way that your Connection Charge is calculated.

Payment Terms

4.2 The Connection Charge is normally payable in full in advance of Energisation of the Connection Works. For simple service connections, where work is minimal, we recommend that payment is made at the same time as you accept our Connection/Point of Connection Offer as this will expedite the programming of the work. The Connection Charge will be payable in stages. In the case of a phased development, or connections requiring major electrical infrastructure, e.g., a housing estate, large commercial development, or large generator. An initial payment may be required at the time you accept the Connection/Point of Connection Offer and further payment will be required by instalment to coincide with our incidences of expenditure.

Minimum Scheme

4.3 The Minimum Scheme is the scheme with the lowest overall capital cost (as estimated by us), solely to provide the Required Capacity. The Minimum Scheme will be subject to:

- accepted industry standards, including the requirements of the Distribution Code.
- the status and configuration of the Relevant Section of the Network (RSN).
- the standard sizes and types of equipment currently used by us on our Distribution System which shall be reasonable in all circumstances.
- maintaining our ability to minimise regulatory penalties associated with the Guaranteed Standards of Performance; and
- where the Customer is an LDNO, maintain the Customer's ability to minimise regulatory penalties associated with the Guaranteed Standards of Performance.

The Minimum Scheme shall also be consistent with our statutory and licence obligations including the requirement to develop, maintain and operate an efficient, coordinated, and economical electricity Distribution System.

4.4 We will make available our design policies and standards as appropriate.

4.5 Subject to paragraphs 4.6 to 4.9 below, we will calculate the Connection Charge based on the estimated costs of the Minimum Scheme.

Enhanced Scheme

- 4.6 In certain circumstances we may decide to design an Enhanced Scheme. This may include one or more of the following:
- additional assets not required as part of the Minimum Scheme.
 - assets of a larger capacity than required by the Minimum Scheme.
 - assets of a different specification than required by the Minimum Scheme.
- 4.7 The Connection Charge associated with the Enhanced Scheme will be calculated subject to the exclusion of costs of any additional assets not necessary for the provision of your connection.
- 4.8 If we decide to design an Enhanced Scheme, then the Connection Charge that we apply will be the lower of the Enhanced Scheme and the Minimum Scheme.
- 4.9 There may be certain circumstances, such as where you require us to undertake work that is over and above that of the Minimum Scheme, where we may require you to contribute to, or pay in full, the costs of the Enhanced Scheme. These circumstances are detailed further in paragraphs 4.13-4.23.

Costs

- 4.10 We may recover the reasonable costs incurred, both directly and indirectly in providing a connection and may, where permitted by our licence, apply a reasonable margin. The factors taken into account by us to calculate the Connection Charge will include, but are not limited to:
- industry standards governing the Distribution System.
 - the Required Capacity.
 - available capacity of the existing Distribution System.
 - whether any necessary extension or Reinforcement of the existing Distribution System is required.
 - whether any diversionary works are required as a result of the developments and required disconnection of any assets.
 - the length of cable required.
 - type of ground requiring excavation, the type and extent of the reinstatement necessary (including New Roads and Street Works Act requirements and any other relevant legislation), and the need for road, bridge crossings etc.
 - any Electrical Plant and civil costs required, allowing for any civil works undertaken by you with our agreement.
 - the cost of installing communication equipment
 - the cost of installing system management equipment
 - the requirement to work outside of normal working hours.
 - the cost of undertaking the design

- the costs of securing easements for plant and cable including any consents.
- the costs of securing suitable substation sites including any necessary Land Rights.
- the costs of public enquiries and environmental impact studies.
- charges for any other costs associate with the work on Sites of Special Scientific Interest (SSSI), railway lines etc.
- any variations in respect of the actual costs that were reasonably incurred as specified in the Connection Offer.
- costs for reinforcing the existing network in order to provide your connection; and,
- costs associated with NRSWA noticing.

Cost Allocation

4.11 The cost charged to you as a connection charge may be split into three categories:

- Costs for providing the connection which are to be paid in full by you (see 4.13 - 4.23).
- Costs to be paid by you in respect of works that have previously been constructed (see 4.41).
- Cost for providing the connection which are to be apportioned between you and us (see 4.35 - 4.40).

4.12 Some costs may be borne in full by us and will not be included in your Connection Charge (see paragraphs 4.42 – 4.45).

Costs to be paid in full by you.

4.13 The costs of providing Extension Assets will be charged in full to you.

4.14 Where, in providing your connection, we incur costs from another electricity network provider (distribution or transmission) we will notify you and these costs will be charged in full to you. This is including but not limited to; design costs, reinforcement or increased capacity costs, land rights costs and connection charges.

4.15 Where you have requirements for additional security, or the characteristic of your load requires us to install assets in excess of the Minimum Scheme then you will be required to pay in full the costs that are in excess of the Minimum Scheme. Where you have requested a three-phase connection and/or a supply voltage that is not necessary to meet the Required Capacity and the local Distribution System is not of the requested number of phases and/or voltage, then you will be required to pay in full the cost of Reinforcement of the Distribution System to your specified number of phases/and/or voltage.

4.16 The costs of the future operation and maintenance of any additional assets requested by you (i.e., assets provided over and above those associated with the Minimum Scheme) may be payable in full by you. This will normally be levied as a one-off charge

representing the net present value of the future operation and maintenance costs as calculated as a percentage specified in paragraph 6.2. of the additional capital cost of the Scheme. See Example 3 for an illustration of where you request additional security.

- 4.17 Work required to reconfigure the Distribution System to meet your requirements where no additional Network or Fault Level Capacity is made available shall be charged in full to you.
- 4.18 Where the Extension Assets would normally require the extension of existing switchgear equipment and this is not possible, the costs of the full replacement of the switchgear (using the nearest standard size) will be charged to you, provided that there is no Reinforcement of the Distribution System.
- 4.19 If your development is considered to be speculative then the Reinforcement costs will be charged to you in full.
- 4.20 Reinforcement costs for the Minimum Scheme in excess of the High-Cost Project Threshold shall be charged to you in full as a Connection Charge. The calculation of this charge will include all costs for Reinforcement carried out at the same Voltage level and on the Voltage level above the Point of Connection to the existing Distribution System. For Generation Connection the threshold is £200/kW; for Demand Connections the threshold is £1,720/kVA. Reinforcement costs below the High-Cost Project Threshold will follow the methodology outlined under paragraphs 4.24 to 4.34. The table below illustrates the application of the High-Cost Project Threshold

England & Wales

Voltage of Scheme Assets	Voltage at the Point of Connection			
	LV (below 1000V)	HV (above 1kV but less than 22kV)	EHV (above 22kV but less than 72kV)	132kV
132kV Network	Excluded from assessment ¹	Excluded from assessment ¹	Included in assessment	Included in assessment
132kV/EHV Substation	Excluded from assessment ²	EHV circuit breakers only included in assessment	Included in assessment	Not Applicable
EHV Network	Excluded from assessment ¹	Included in assessment	Included in assessment	Not Applicable
132kV/HV Substation	HV circuit breakers only included in assessment	Included in assessment	Not Applicable	Not Applicable

¹ Except where there is direct transformation from 132kV to HV or EHV to LV when the higher voltages are included

² Except where there is direct transformation from 132kV to HV or EHV to LV when the higher voltage circuit breaker costs are included

EHV/HV Substation	HV circuit breakers only included in assessment	Included in assessment	Not Applicable	Not Applicable
EHV/LV Substation	Included in assessment	Not Applicable	Not Applicable	Not Applicable
HV Network	Included in assessment	Included in assessment	Not Applicable	Not Applicable
HV/LV Substation	Included in assessment	Not Applicable	Not Applicable	Not Applicable
LV Network	Included in assessment	Not Applicable	Not Applicable	Not Applicable

NB: The table above may not accommodate every possible set of circumstances, where this is the case, the Voltage Level (as defined in the Glossary) shall be applied.

Scotland

Voltage of Scheme Assets	Voltage at the Point of Connection		
	LV (below 1000V)	HV (above 1kV but less than 22kV)	EHV (above 22kV but less than 72kV)
EHV Network	Excluded from assessment ¹	Included in assessment	Included in assessment
EHV/HV Substation	HV circuit breakers only included in assessment	Included in assessment	Not Applicable
EHV/LV Substation	Included in assessment	Not Applicable	Not Applicable
HV Network	Included in assessment	Included in assessment	Not Applicable
HV/LV Substation	Included in assessment	Not Applicable	Not Applicable
LV Network	Included in assessment	Not Applicable	Not Applicable

NB: The table above may not accommodate every possible set of circumstances, where this is the case, the Voltage Level (as defined in the Glossary) shall be applied.

4.21 To facilitate the Maximum Capacity requested by you in your connection application, we may be required to pay additional charges to the operator of the Distribution System

¹ Except where there is direct transformation from 132kV to HV or EHV to LV when the higher voltages are included

to which our network connects. The upstream network operator will be required to calculate these charges in accordance with their connection charging methodology. Where we receive charges from the upstream network operator, we will pass such charges on to you as part of the overall Connection Charge.

- 4.22 At the time of publication of this document we do not have any connections to the Transmission System. However, should your connection result in any works being undertaken on the Transmission System then these costs will be calculated according to their methodology and included in your Connection Charge.
- 4.23 If you choose not to pay (i) Reinforcement costs for the Minimum Scheme for a Non-Curtailable Connection or (ii) Reinforcement costs in excess of the high-cost project threshold for a Non-Curtailable Connection, then you can request an enduring Curtailable Connection instead (i.e. one which will not convert to a Non-Curtailable Connection in the future). If you subsequently require a Non-Curtailable Connection, then this would require a new connection request which may still be subject to Reinforcement costs, potentially in excess of the high-cost project threshold.

Costs of Reinforcement

- 4.24 Reinforcement is defined as assets installed that add capacity (network or fault level) to the existing shared use Distribution System.
- 4.25 For Generation Connections, where Reinforcement is at the same Voltage Level of the voltage at the POC to the existing Distribution System, then the costs of the reinforcement shall be apportioned between you and us, unless other exceptions apply which take precedence. The methods used to apportion the costs of Reinforcement are set out in paragraphs 4.35 to 4.40.
- 4.26 For Demand Connections, the costs of Reinforcement will be paid in full by us, unless other exceptions apply which take precedence.
- 4.27 Where one of the exceptions set out in paragraphs 4.28 to 4.33 applies, Reinforcement will be treated as Extension Assets and the costs of the Reinforcement will not be apportioned or paid in full by us. The application of the exceptions is demonstrated in the Examples.
- 4.28 **Exception 1:** Where the Reinforcement is:
- downstream of the POC; and
 - over and above the Minimum Scheme; and
 - provided at our request; and
 - provided by connecting two points on the existing Distribution System; and
 - there is little or no prospect of the capacity created being required within the next five years,

then the apportionment rules will not apply. You will be required to pay the costs associated with the Minimum Scheme and we will pay the costs over and above the Minimum Scheme. See Example 2B.

4.29 **Exception 2:** Where the Reinforcement is in excess of the Minimum Scheme and is at your request, the Reinforcement will be treated as Extension Assets and the apportionment rules will not apply. The costs in excess of the Minimum Scheme will be borne in full by you (see paragraphs 4.13 to 4.23 above).

4.30 **Exception 3:** Where the Reinforcement is provided to accommodate a Temporary Connection the Reinforcement will be treated as Extension Assets and the apportionment rules will not apply. Consequently, in such circumstances, you will pay in full the costs associated with the Temporary Connection. Temporary Connections are defined as connections that are only required for a period of up to five years, but exclude connections to provide the initial connection to a development, where the Reinforcement will subsequently be required for the permanent connection.

4.31 **Exception 4:** Where the replacement of switchgear results in an increase in fault level capacity and:

- that increase is solely as a result of the fault level rating of the standard switchgear equipment used by us being higher than that of the existing switchgear; and
- that increase in fault level capacity is not needed to accommodate your connection

then, unless the switchgear adds network capacity and the Security CAF applies, the switchgear replacement will be treated as Extension Assets and the apportionment rules will not apply. Consequently, in such circumstance, you will be required to pay the full cost of the switchgear replacement. See Example 15.

4.32 **Exception 5:** Where the Minimum Scheme requires Reinforcement that is provided by connection two points on the existing Distribution System to provide connectivity to your Premises, then the lowest cost feeder shall be treated as an Extension Asset and all other feeders required to connection your Premises shall be treated as Reinforcement. See Example 17.

4.33 **Exception 6:** Where the Reinforcement:

- is provided by connecting two points on the existing Distribution System; and
- is providing connection to a development with a number of Entry/ Exit Points,

then the additional network length (measured from suitable points close to the site boundaries which would allow for a clear demarcation of Contestable and NonContestable Work) required to provide connectivity within the development will be considered to be Extension Assets and the apportionment rules will not apply. You will pay the full cost of the additional network length. See Example 8A.

4.34 For avoidance of doubt, where Reinforcement costs are borne by you and any capacity created is used to accommodate new or increased connections within the ECCR Prescribed Period, then the provisions of the ECCR will apply (see paragraphs 4.50 - 4.53).

Costs to be apportioned between you and us

4.35 The costs of Reinforcement will be apportioned using one of two Cost Apportionment Factors (CAFs), dependent upon which factor is driving the requirement for Reinforcement:

- The 'Security CAF;' and
- The 'Fault Level CAF.'

4.36 The following definitions are used in the application of the CAFs.

<p>Existing Capacity</p>	<p>For existing Customers, their Existing Capacity will be either: -</p> <p>a) the Chargeable Capacity used in the calculation of their use of system charges; or</p> <p>b) for Customers who are not charged for use of system on the basis of their Chargeable Capacity the lower of:</p> <ul style="list-style-type: none"> • No. of phases x nominal phase-neutral voltage (kV) x fuse rating (A); and • The rating of the service equipment.
<p>Fault Level Contribution from Connection</p>	<p>is the assessment of the Fault Level contribution from the equipment to be connected taking account of its impact at the appropriate point on the Distribution System. Where an existing Customer requests a change to a connection then the "Fault Level Contribution from Connection" is defined as the incremental increase in Fault Level caused by the Customer.</p>
<p>New Fault Level Capacity</p>	<p>is the Fault Level rating, following Reinforcement, of the equipment installed after taking account of any restrictions imposed by the local network Fault Level capacity. For the avoidance of doubt this rule will be used for all equipment types and voltages.</p>
<p>New Network Capacity</p>	<p>is either the secure or non-secure capacity of the Relevant Section of Network (RSN) following Reinforcement. Whether secure or nonsecure capacity is applicable depends upon the type of capacity that can be provided from the RSN. For example, if the capacity provided to the Customer by the RSN is secure, but the capacity requested by the Customer at the point of connection is non-secure, the secure capacity will be used. See Example 12.</p> <p>The capacity to be used will be based on our assessment of the thermal ratings, voltage drop and upstream restrictions and compliance with our relevant design, planning and security of supply policies. The equipment ratings to be used are the appropriate operational rating at the time of the most onerous operational conditions taking account of seasonal ratings and demand.</p>

<p>Relevant Section of Network (RSN)</p>	<p>is that part or parts of the Distribution System which require(s) Reinforcement. Normally this will comprise:</p> <ul style="list-style-type: none"> the existing assets, at the voltage level that is being reinforced, that would have been used to supply you (as far as they have not been replaced) had sufficient capacity been available to connect you without Reinforcement; and/or the new assets, at the same voltage level, which are to be provided by way of Reinforcement. <p>Where it is unclear what assets would have supplied the Customer in the event that sufficient capacity had been available, the existing individual assets with the closest rating to the new assets will be used. See Example 12.</p> <p>There may be more than one RSN (e.g., at different voltage levels).</p>
<p>Required Capacity</p>	<p>is the Maximum Capacity agreed with the Customer. In the case of multiple connections (e.g., a housing development) it may be adjusted after consideration of the effects of diversity. Where an existing Customer requests an increase in capacity then it is the increase above their Existing Capacity.</p>

4.37 The 'Security CAF' is applied, where the costs are driven by either thermal capacity or voltage (or both) as assessed against the relevant standard. This rule determines the proportion of the Reinforcement costs that should be paid by you as detailed below.

$$\text{Security CAF} = \frac{\text{Required Capacity}}{\text{New Network Capacity}} \times 100\% \quad (\text{max } 100\%)$$

4.38 The 'Fault Level CAF' is applied, where the costs are driven by Fault Level restrictions. This rule determines the proportion of the Reinforcement costs that should be paid by you as detailed below.

$$\text{Fault Level CAF} = 3 \times \frac{\text{Fault Level Contribution from Connection}}{\text{New Fault Level Capacity}} \times 100\% \quad (\text{max } 100\%)$$

4.39 For clarity, where you require an augmentation to an existing connection, both the Security and Fault Level CAFs will be based on the increase in Required Capacity and increase in Fault Level Contribution from the connection, respectively. Any related increases within the previous three-year period will be taken into account in determining the increase in the Required Capacity or increase in the Fault Level Contribution from the connection to be applied within the CAF.

4.40 On some schemes there may be interaction between the two rules. In such cases, the 'Security' CAF will be applied to costs that are driven by the security requirements. The 'Fault Level CAF' will be applied to costs that are driven by Fault level requirements. See the examples for illustrations on the application of the CAFs.

Recovery of costs for previous works

4.41 Where, in order to provide your connection:

- we propose to utilise existing Distribution System assets that were previously installed to provide a connection to another Customer; and
- the other Customer has paid us (either in part or in full) a Connection Charge for those assets or paid an ICP for those assets which were then adopted by us; then,

you may be required to make a payment towards them. The ECCR prescribes the circumstances where such payment is required. Charges for such works only apply where the new connection is provided within the ECCR Prescribed Period.

Costs to be paid in full by us.

4.42 Where assets are installed at our request that are above the cost of the Minimum Scheme then you will be required pay the costs associated with the Minimum Scheme and we will pay the costs over and above the Minimum Scheme.

4.43 For Demand Connections we will fully fund all Reinforcement. For Generation Connections, we will fully fund Reinforcement carried out on our Distribution System at a Voltage Level higher than above the Voltage Level at the Point of Connection to our Distribution System. However, there are exceptions too these two approaches, as set out elsewhere in this methodology.

The tables below illustrate the application of the voltage rules in relation to Reinforcement for Demand and Generation Connections. For Generation Connections you will be required to contribute towards the cost of any Reinforcement provided at the Voltage Level of the Point of Connection up to and including the cost of circuit breakers provided at that voltage.

England and Wales – Demand Connections

Voltage of Scheme Assets	Voltage at the Point of Connection			
	LV (below 1000V)	HV (above 1kV but less than 22kV)	EHV (above 22kV but less than 72kV)	132kV
132kV Network	We Fund	We Fund	We Fund	We Fund
132kV/EHV Substation	We Fund	We Fund	We Fund	Not applicable
EHV Network	We Fund	We Fund	We Fund	Not applicable
132kV/HV Substation	We Fund	We Fund	Not applicable	Not applicable
EHV/HV Substation	We Fund	We Fund	Not applicable	Not applicable
EHV/LV Substation	We Fund	Not applicable	Not applicable	Not applicable
HV Network	We Fund	We Fund	Not applicable	Not applicable
HV/LV Substation	We Fund	Not applicable	Not applicable	Not applicable
LV Network	We Fund	Not applicable	Not applicable	Not applicable

England and Wales – Generation Connections

Voltage of Scheme Assets	Voltage at the Point of Connection			
	LV (below 1000V)	HV (above 1kV but less than 22kV)	EHV (above 22kV but less than 72kV)	132kV
132kV Network	We Fund	We Fund	We Fund	Apportioned
132kV/EHV Substation	We Fund	We Fund	EHV circuit breakers only Apportioned	Not applicable
EHV Network	We Fund	We Fund	Apportioned	Not applicable
132kV/HV Substation	We Fund	HV circuit breakers only Apportioned	Not applicable	Not applicable
EHV/HV Substation	We Fund	HV circuit breakers only Apportioned	Not applicable	Not applicable
EHV/LV Substation	LV Board only Apportioned	Not applicable	Not applicable	Not applicable
HV Network	We Fund	Apportioned	Not applicable	Not applicable
HV/LV Substation	LV Board only Apportioned	Not applicable	Not applicable	Not applicable
LV Network	Apportioned	Not applicable	Not applicable	Not applicable

Scotland – Demand Connections

Voltage of Scheme Assets	Voltage at the Point of Connection		
	LV (below 1000V)	HV (above 1kV but less than 22kV)	EHV (above 22kV but less than 72kV)
EHV Network	We Fund	We Fund	We Fund
EHV/HV Substation	We Fund	We Fund	Not applicable
EHV/LV Substation	We Fund	Not applicable	Not applicable
HV Network	We Fund	We Fund	Not applicable
HV/LV Substation	We Fund	Not applicable	Not applicable
LV Network	We Fund	Not applicable	Not applicable

Scotland – Generation Connections

Voltage of Scheme Assets	Voltage at the Point of Connection		
	LV (below 1000V)	HV (above 1kV but less than 22kV)	EHV (above 22kV but less than 72kV)
EHV Network	We Fund	We Fund	Apportioned
EHV/HV Substation	We Fund	HV circuit breakers only Apportioned	Not applicable
EHV/LV Substation	LV Board only Apportioned	Not applicable	Not applicable
HV Network	We Fund	Apportioned	Not applicable
HV/LV Substation	LV Board only Apportioned	Not applicable	Not applicable
LV Network	Apportioned	Not applicable	Not applicable

Where another LDNO with a distribution network that is connected to our Distribution System requires an increase in capacity to its distribution network, the voltage at the POC for assessing the voltage rule will be:

- In the case of a new extension to the network of the other LDNO, the voltage of connection at which the Extension Assets will connect to the other LDNO's network; or
- In the case of additional capacity required in respect of a Customer connected to the existing assets of the LDNO, the voltage at which the Customer connects to the LDNO's network; or
- In the case of additional capacity required to meet general load growth on the LDNO's network then the Reinforcement costs will be borne by

us. The LDNO will be required to provide justification in such circumstances.

4.44 We will fully fund Reinforcement carried out to allow the installation of all equipment at an existing premises which remain connected via an existing low-voltage single, two or three phase service fused at 100 amperes or less per phase which is metered with whole-current metering; provided that (to the extent relevant):

- the Reinforcement is carried out to allow the installation of equipment as part a single application for a single or multiple installations;
- any and all electricity generation equipment installed has a rated output not greater than 16 amperes per phase (or not greater than 16 amperes per phase at any single premises if a single application for multiple installations);
- any and all equipment installed which does not constitute a modification to the existing service conforms with the technical requirements of the following standards (notwithstanding that the equipment may have an input current that is more than 16 amperes per phase):
- BS EN 61000-3-2 Electromagnetic compatibility (EMC) Limits. Limits for harmonic current emissions (equipment input current ≤ 16 A per phase); and
- BS EN 61000-3-3 Electromagnetic compatibility (EMC). Limits. Limitation of voltage changes, voltage fluctuations and flicker in public low-voltage supply systems, for equipment with rated current ≤ 16 A per phase and not subject to conditional connection

4.45 Where it is necessary to modify a low-voltage single phase looped service for an existing premise, this shall be considered to have remained connected under Paragraph 4.37 above.

Additional Cost Allocation for Flexible Connections and Curtailable Connections

4.46 To Facilitate the provision of a Flexible Connection or a Curtailable Connection, we may need to install and maintain specific system management equipment, at your Premises and/or further upstream in other parts of the Distribution System. Some of the costs associated with installing, operating and maintaining the system management equipment will be directly attributed to your connection and be included as part of your Connection Charge (see illustrative table in paragraph 4.46). The proportion of the costs which you must fund depends on whether your connection forms part of a Dedicated Scheme or a Wide Area Scheme, as described below:

- Type 1 - Dedicated Scheme: A scheme managing constraint(s) where there are no Customers downstream of the constraint(s) who could connect new or additional demand or generation without being controlled by the Dedicated Scheme:
- Type '1A' considers a scenario involving only one customer; and

- Type '1B' considers a scenario involving multiple customers.
- Type 2 – Wide Area Scheme: A scheme managing constraint(s) where there are Customers downstream of the constraint(s) who could connect new or additional demand or generation without being controlled by the Wide Area Scheme

4.47 The table below illustrates the scheme types and methodology for cost recovery associated with each type of Flexible Connection or a Curtailable Connection. The methodology covers Type 1A, Type 1B and Type 2 (as each is described in paragraph 5.32A)

Typical Connection Components ¹	Type 1A – Single	Type 1B – Multiple	Type 2 – Wide Area
Extension Assets for Customer	You Fund	You Fund	You Fund
End user control unit for the customer	You Fund	You Fund	You Fund
Local system management unit	You Fund	Shared equally between participants	We Fund
Scheme management unit	You Fund	Shared equally between participants	We Fund
Central management unit	N/A	N/A	We Fund
Scheme specific ongoing costs e.g. communications	We Fund	We Fund	We Fund

¹We will describe the main connection components within the relevant connection offer, which will also include the funding arrangements for each such connection component (if different to that stated in this illustrative table)

Recovered Equipment and Deferral of Asset Replacement

4.48 Normally, you will not receive any credit for the value of any equipment recovered by us as a result of providing a connection. However, where a Temporary Connection is to be disconnected, we will determine the value of recovered equipment that we can subsequently re-use (net of depreciation and removal and refurbishment costs). Where there is a net value in the recovered equipment that can be re-used, we will pay you the amount of such net value subject to a de minimis level of £100. The value will be based on the reasonable costs of:

- Determining whether the equipment can be re-used;
- Calculating the refund; and
- Processing any credit.

4.49 You will not receive any credit for the value of any deferment of asset renewal expenditure by us.

Rebates

4.50 For Distribution System assets where you have paid in full, you may be entitled to a future reimbursement payment under the ECCR should another Customer connect to those assets. These circumstances are detailed in the ECCR.

4.51 For Distribution System assets where you have paid in proportion to your Required Capacity, then you are not entitled to a future rebate of charges should another Customer connect to those assets.

4.52 Your entitlement to receive payments under the ECCR only applies to connections made within the ECCR Prescribed Period from the first provision of the connection.

4.53 These provisions do not apply where your connection was made before 6 April 2017, and we have adopted the assets from an ICP. However, for connections made on or after 6 April 2017, these provisions do apply to assets we have adopted from an ICP (as further described in the ECCR).

Speculative Developments

4.54 Applications will be assessed to determine whether they are a Speculative Development by using the Speculative Developments scoring system described in paragraphs 4.55-4.73, which will be applied as follows:

- Consideration will be given to the fact that some aspects of an application may have a greater bearing on whether the application should be considered as not being a Speculative Development. In recognition of this, the criteria used in the scoring system are weighted as either high or low significance.
- Only the points identified in the scoring criteria shall be placed against each respective criterion that is relevant to the application. Each high significance criterion shall be scored 2 points and each low significance criterion shall be scored 1 point, without exception.
- The number of points entered in the 'speculative' and 'non-speculative' columns shall be added up to give a total number for the respective column, as shown in the scoring proforma below.
- If the total value of points for the 'speculative' column is greater than the total value of points for the 'non-speculative' column, then the application will be considered as being a Speculative Development.
- If there is no score in either column, then we reserve the right to obtain additional information prior to making the assessment.
- All criteria may not apply to every application.

Scoring Proforma		
Criteria	Non-Speculative Points	Speculative Points
1		

2		
3		
4		Not Applicable
5		
6		Not Applicable
Total Points:		

Criterion 1: Programme (domestic and non-domestic developments)

4.55 This criterion is deemed to be of low significance.

4.56 The application will receive points in the 'non-speculative' column, if:

- The development has an overall timescale of up to two years from the date the initial application is made until the completion of the final phase; or
- The applicant has provided a clear phasing plan for the complete development.

4.57 The application will receive points in the 'speculative' column if:

- The development has an overall timescale of more than ten years from the date the initial application is made to the completion of the final phase; and
- The applicant does not provide a clear phasing plan for the complete development;

4.58 Should the Customer's Development be phased over a period greater than two years but less than or equal to ten years, then no points shall be entered in either the 'speculative' or 'non-speculative' columns.

Criterion 2: Programme (domestic developments only)

4.59 This criterion is deemed to be of high significance.

4.60 The application will be receiving points in the 'non-speculative' column if the complete development comprises less than 100 dwellings or requires less than three permanent HV/LV substations beyond the POC.

4.61 The application will receive points in the 'speculative' column, if the complete development includes more than 5,000 dwellings or requires more than ten permanent HV/LV substations beyond the POC.

4.62 Should the characteristics of the customer's development fall between these two thresholds, then no-points shall be entered in either of the 'speculative' or 'nonspeculative' columns.

Criterion 3: Load Profile

4.63 This criterion is deemed to be of high significance.

4.64 The application will receive points in the 'non-speculative' column if the application is for a development that is (or will become) a Phased Capacity Site.

4.65 The application will receive points in the 'speculative' column if the applicant does not provide an acceptable (to us) capacity ramp profile and a portion of the Required Capacity is for future expansion.

Criterion 4: Financial Commitment

4.66 This criterion is deemed to be of low significance.

4.67 The application will receive points in the 'non-speculative' column if the applicant makes a finance commitment in support of the application. A financial commitment is made where the applicant agrees to pay for:

- Assets installed at initial connection which are sized differently to accommodate the complete future development, and which are greater than the assets to accommodate the capacity to be utilised in the early phases of construction; and
- Any operation and maintenance costs for such increased assets which may be included within the connection offer prior to the initial energisation of the connection.

Criterion 5: Future Provision

4.68 This criterion is deemed to be of high significance.

4.69 The application will receive points in the 'non-speculative' column if at least 75% of the total connections and/or at least 75% of the total load are delivered in the first phase of the development (excluding any temporary works).

4.70 The application will receive points in the 'speculative' column if only infrastructure is being provided, with no connections for end users requested, and the development is not within the relevant local authority's development plans.

Criterion 6: Planning Permission

4.71 The application will receive points in the 'non-speculative' column reflective of a high significance criterion if the complete development has achieved Full Planning Permission.

4.72 The application will receive points in the 'non-speculative' column reflective of a low significance criterion if the complete development has only achieved Outline Planning Permission.

4.73 For clarity the absence of planning permission/consent for the development will not result in any points being added to the 'speculative' column.

Connection Alterations

4.74 Where you request an alteration to your connection arrangements, including a change in the supply voltage, the costs will be charged in full to you. For the avoidance of doubt increases in the Required Capacity are dealt with in accordance with previous sections.

Capacity Ramping for LDNOs

4.75 For an LDNO the Required Capacity (expressed in kVA) is the Maximum Capacity to be provided at the boundary between the LDNO's distribution Network and our Distribution System. This value will be agreed with us and stated in the Bilateral Connection Agreement for the relevant embedded network.

- 4.76 When a connection is provided to an LDNO the take-up of capacity may grow over a period of time as the site develops and individual customers are connected. In such circumstances the Bilateral Connection Agreement may include a phased Required Capacity based on the Development Phase.
- 4.77 During the Development Phase a review may be undertaken annually on the anniversary of the Energisation of the embedded network. Any unused capacity identified in such review may be released for use by other customers and the Maximum Capacity reduced to an agreed level within the Bilateral Connection Agreement.
- 4.78 The Required Capacity agreed with us as being required at the end of the Development Phase shall be used to determine the Required Capacity for determination of the Cost Apportionment Factors where applicable.
- 4.79 Should additional capacity subsequently be required, the LDNO may incur additional Connection Charges for any Reinforcement based on the increase in capacity.

Competition in Connection Charges

- 4.80 Should you choose to have any Contestable Work undertaken by an ICP, we will not levy Competition in Connection Charges associated with design approval, inspection, and adoption of the Contestable works.

Land Rights

- 4.81 Where Land rights are required from a third party, the costs of acquiring those rights will be included in either the Connection Charge to you or through a separate mechanism agreed between you and us.
- 4.82 If the land rights that we require cannot be obtained by negotiation, we may, following discussion with you, exercise our powers of compulsory purchase (Section 10 and Schedule 3 of the Act) or apply to the Secretary of State or the Scottish Government in Scotland for a 'necessary wayleave' (paragraphs 6-8 of Schedule 4 of the Act). If we do so, the costs that we incur, including those of the Lands Tribunal/Lands Tribunal for Scotland (which determine issues of compensation) will be charged to you. The Lands Tribunal may award compensation to the landowner and/or anyone who holds an interest in the land, and this will be included in the Connection Charge or through a separate mechanism agreed between you and us.
- 4.83 We require the transfer of the freehold or alternatively the grant of long leasehold of any substation site which forms part of the Contestable or Non-Contestable Works.
- 4.84 We require the grant of a permanent easement (deed of grant) for any Electric Line cable that forms part of the Contestable or Non-Contestable Works which does not fall within land deemed adopted highway.

Unmetered Supplies

- 4.85 For some street lighting and other installations, we may allow items of equipment to be connected to our Distribution System without a meter. This is subject to the equipment having a low and predictable pattern of consumption and meeting the requirements of The Electricity (Unmetered Supply) Regulations 2001.

- 4.86 Where we agree that a meter is not required the provision of such a connection is dependent on the owner entering into an unmetered Connection Agreement and providing and maintaining an auditable inventory, in a format agreed with us, so that an accurate estimate of the consumption can be produced.
- 4.87 Where certain criteria are met the provision of services for unmetered connections may be made via time-based connection service charge, e.g., Rent-a-Jointer Services. This is subject to us entering a contract with you for the provision of such services.
- 4.88 You may elect an accredited ICP to carry out the Contestable Work for unmetered connections. The ICP will be allowed to carry out live jointing on low voltage underground cables. Where you use an ICP, arrangements must first be established as follows:
- you will enter into an agreement with the ICP to carry out and complete the contestable work; and
 - we will enter into an agreement and/or an Adoption Agreement with you and/or your appointed ICP as appropriate.

Disconnection

4.89 If we Disconnect your Entry/ Exit point:

- at your request; or
- due to the failure by you to comply with the terms of your connection agreement

then the cost of such disconnection will be borne by you.

4.90 If you terminate your Connection Agreement, we retain the right to remove our Electrical Plant and Electrical Lines and charge you if we do so. Apparatus which is not cost effective for us to recover (e.g., Electric Lines laid underground) will normally be made safe and left at the Premises, but if you require us to remove the Apparatus, the cost of removal will be payable by you. All such apparatus will remain our property unless otherwise agreed in writing.

Phased Capacity Site

- 4.91 If a Customer has a requirement for capacity to increase over a period of time, then a phased Required Capacity can be agreed. The phased Required Capacity will be documented in the Connection Agreement for the connection.
- 4.92 We will use the phased Required Capacity to assess the needs of the Distribution System and what, if any, Reinforcement is required. Any Reinforcement will be charged in accordance with the Charging Methodology for a Demand Connection or Generation Connection, as appropriate.
- 4.93 We will use the phased Required Capacity, updated in the Connection Agreement and as applicable at the relevant time, as the Maximum Capacity for the purposes of the calculating the Customer's use of System Charges.

- 4.94 By agreeing a phased Required Capacity, the Customer is committing to pay, from Energisation of the connection, Use of System Charges based upon the residual charging band allocated in accordance with DCUSA Schedule 32 (Residual Charging Bands) based on the Required Capacity for the complete development. For example, if the connection will be ramped from 1MVA to 5MVA over 10 years, the Customer is committing to pay Use of System Charges for a 5MVA connection in line with the ramped profile (i.e. when the capacity is ramped to 5MVA in year 10). For the avoidance of doubt, the capacity charges during the period that the capacity is being ramped will be calculated according to the Required Capacity for the relevant time period as defined by the ramped capacity profile for the connection.
- 4.95 During the Development Phase a review may be undertaken annually on or around the anniversary of the date of Energisation of the connection. The results of that review will be discussed, and where appropriate we may require reasonable changes to the phasing as a result of that review.

5 Worked examples illustrating the application of the connection charging methodology.

The following examples are to illustrate the application of the Connection Charging Methodology and are not intended to provide an accurate estimate of the charges a person would become liable for in respect of the provision of a connection. The examples do not necessarily represent the Minimum Scheme for a specific connection application.









The figures quoted in the examples are illustrative only. Section 7 of this statement provides our charges and indicative costs to undertake various activities (which may differ from the costs shown in these examples, with the costs shown in Section 7 always taking precedence).

The examples illustrate where we undertake both the Contestable and Non-Contestable Work. These costs will include the determination of the Point of Connection and assessment and design costs, though these may not be explicitly identified in the examples.

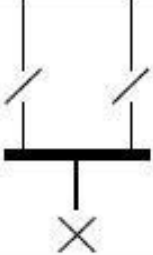
Where Contestable Work is undertaken by an ICP, we will not apply CIC Charges for services associated with the Contestable Works which would cover activities including design approval, inspection, and monitoring. For the avoidance of doubt, in each example, where an ICP undertakes the Contestable Work, our Connection Charge will include the cost of the Non-Contestable Work but exclude the cost of Contestable Work.

The examples are generic and standard for all LDNOs, but they do not represent the network analysis and subsequent design solutions that would be completed for an actual connection scheme. The actual designs are subject to our design polices.

Key to Illustrations

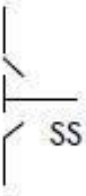
X	Circuit Breaker (any voltage)
	Switch
	Transformer
	Joint on cable
	High voltage ring main unit
	Existing cable
	Proposed cable
	Normal Open Point (NOP)
	Generator Customer
	Demand Customer
	Point of Connection (POC)
	Sub Station

Example 1: A new connection to a domestic premise

A Customer requests a LV single phase connection to a new house. The Premises can be connected to an existing LV main cable in the street.

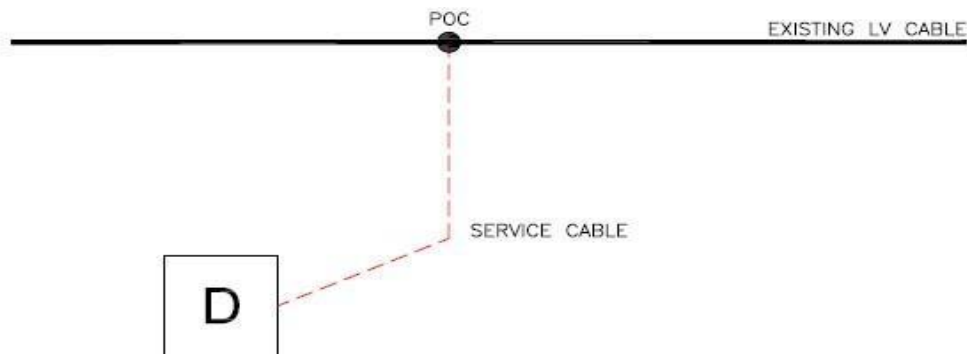

The Connection Charge for this Scheme is calculated as follows:

Extension Assets	Cost	Apportionment	Customer Contribution
15m service cable, excavation in footpath for joint hole to Customer laid duct, backfill and termination	£1,600	n/a	£1,600
Single service breach joint	£300	n/a	£300
Total Extension Asset Cost			£1,900

Example 2: New connections on a domestic housing development

A housing developer requests connections for 200 domestic Premises. The Required Capacity to supply the 200 homes is 250kVA. A new distribution substation will be established to provide the Required Capacity of the site. The Minimum Scheme requires the substation to be looped into the existing HV network.

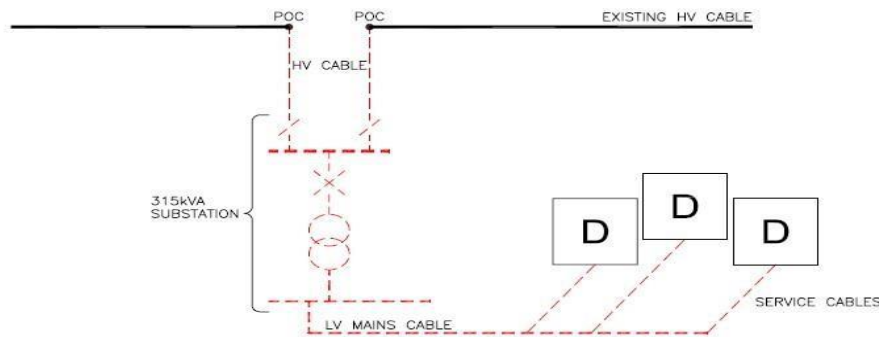

The Connection Charge for this Scheme is calculated as follows:

Extension Assets	Cost	Apportionment	Customer Contribution
Provision and installation 100m HV cable	£30,000	n/a	£30,000
315kVA substation	£60,000	n/a	£60,000
LV mains, service cables and terminations	£200,000	n/a	£200,000
Two HV cable joints	£6,000	n/a	£6,000
Total Extension Asset Cost			£296,000

Example 3: New connections on a domestic housing development with interconnection requested by Customer

As in Example 2, a housing developer requests connections for 200 domestic Premises. The Required Capacity to supply the 200 homes is 250kVA. A new distribution substation will be established to provide the Required Capacity of the site. The Minimum Scheme requires the substation to be looped into the existing HV network. However, in this Example there is an option to provide an additional LV cable to interconnect the distribution substation with the existing LV network. This option is over and above the Minimum Scheme.

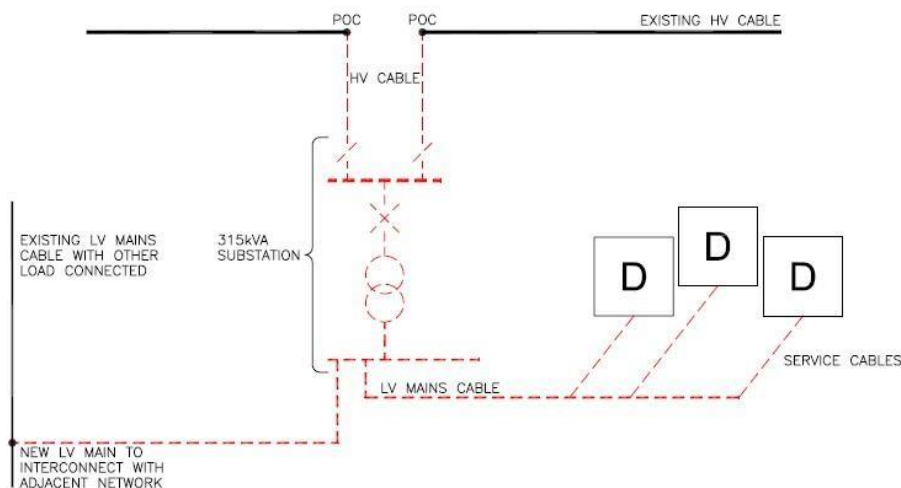

Interconnecting into the existing LV network will increase the capacity of the existing Distribution System. Therefore, the assets that connect the HV and LV network would normally be considered to be Reinforcement. These assets (as shown on the diagram above) include the HV cable, the 315kVA substation and the interconnecting LV main. They exclude the LV mains and service cables from the 315kVA substation to the Customer's development. However, whether these assets are to be considered Reinforcement or Extension Assets depends upon who requested the LV interconnection and whether any capacity created is likely to be used. One of three scenarios will apply:

In this case Exception 2 applies as the LV interconnector is over and above the Minimum Scheme and requested by the Customer. Therefore, all assets (including the interconnecting LV cable) will be treated as Extension Assets and their costs will be borne in full by the Customer. As the interconnecting LV main and associated LV joint are over and above the Minimum Scheme, a charge for their future operation and maintenance will be made.

The Connection Charge for this Scheme is calculated as follows:

Extension Assets	Cost	Apportionment	Customer Contribution
Provision and installation 100m 11kV cable (from existing HV network to substation)	£30,000	n/a	£30,000
315kVA substation	£60,000	n/a	£60,000
LV mains, service cables and terminations (from substation to the Customer's development)	£200,000	n/a	£200,000
Interconnecting LV Cable (From substation to existing LV network)	£12,000	In excess of Minimum Scheme (requested by Customer)	£12,000
Two HV cable joints	£6,000	n/a	£6,000
LV cable joint	£300	In excess of Minimum Scheme (requested by Customer)	£300
Difference between Minimum and the actual Scheme is £12,300. Operation & Maintenance @20%* of £12,300		n/a	£2,460
Total Extension Asset Cost	£308,300		£310,760

*Note, the 20% Operation and Maintenance figure is illustrative.

Example 4: New connections on a domestic housing development with interconnection requested by us

As in Example 2, a housing developer requests connections for 200 domestic Premises. The Required Capacity to supply the 200 homes is 250kVA. A new distribution substation will be established to provide the Required Capacity of the site. The Minimum Scheme requires the substation to be looped into the existing 11kV network. However, in this Example there is an option to provide an additional LV cable to interconnect the distribution substation with the existing LV network. This option is over and above the Minimum Scheme.

Interconnecting into the existing LV network will increase the capacity of the existing Distribution System. Therefore, the assets that connect the 11kV and LV network would normally be considered to be Reinforcement. These assets (as shown on the diagram below) include the 11kV cable, the 315kVA substation and the interconnecting LV main. They exclude the LV mains and service cables from the 315kVA substation to the Customer's development. However, whether these assets are to be considered Reinforcement or Extension Assets depends upon who requested the LV interconnection. In this case all the requirements of Exception 1 (paragraph 1.22) are met so the assets that connect the existing 11kV and LV Distribution System will be treated as Extension Assets. The Customer will pay the costs associated with the Minimum Scheme in full. The interconnecting LV cable and associated LV joint, as they are over and above the Minimum Scheme and were requested by us, therefore the costs will be borne in full by us.

The Connection Charge for this Scheme is calculated as follows:

Extension Assets	Cost	Apportionment	Customer Contribution
Provision and installation 100m 11kV cable (from existing HV network to substation)	£30,000	n/a	£30,000
315 kVA substation	£60,000	n/a	£60,000
LV mains, service cables and terminations (from substation to the Customer's development)	£200,000	n/a	£200,000
Two HV cable joints	£6,000	n/a	£6,000
Interconnecting LV Cable (from substation to existing LV network)	£12,000	In excess of Minimum	£0
LV Cable Joint	£300	In excess of Minimum	£0
Total Extension Asset Cost	£308,300		£296,000

Example 5: A new connection where the Minimum Scheme is a new substation teed onto the existing HV network

A Customer requests a new LV three phase 600kVA connection to commercial Premises. Four scenarios for connection are considered in examples 5 to 8. The Minimum Scheme will be dependent on the specific circumstances as set out in paragraphs 4.3 to 4.5.

In this example the Minimum Scheme is a new 800kVA substation teed onto the existing 11kV network. The figure below shows the proposed network.

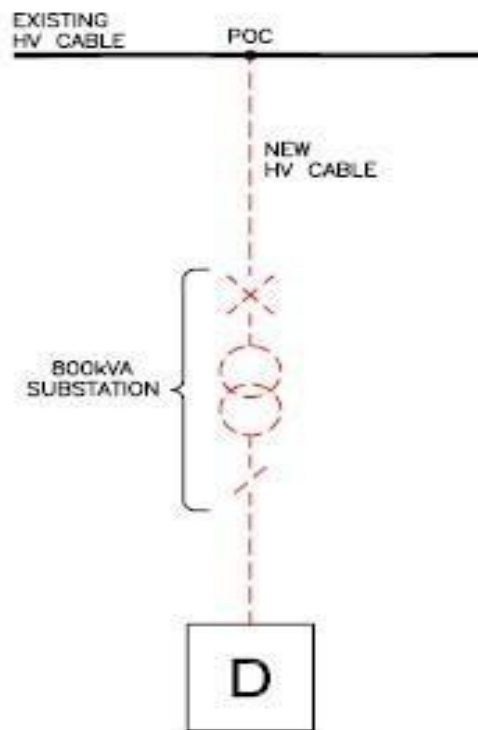

The Connection Charge for this Scheme is calculated as follows:

Extension Assets	Cost	Apportionment	Customer Contribution
Provision and installation of 150m of HV cable	£45,000	n/a	£45,000
800kVA substation	£85,000	n/a	£85,000
Provision and installation LV cabling	£6,000	n/a	£6,000
Metering panel	£4,000	n/a	£4,000
HV joint to network	£3,000	n/a	£3,000
Total Extension Asset Cost	£143,000		£143,000

Example 6: A new connection where the Minimum Scheme is a new substation looped into the existing HV network

In this variation to Example 5, the Customer is connected with a looped connection, as illustrated in the following diagram. The Minimum Scheme is a new 800kVA substation looped into existing 11kV network.

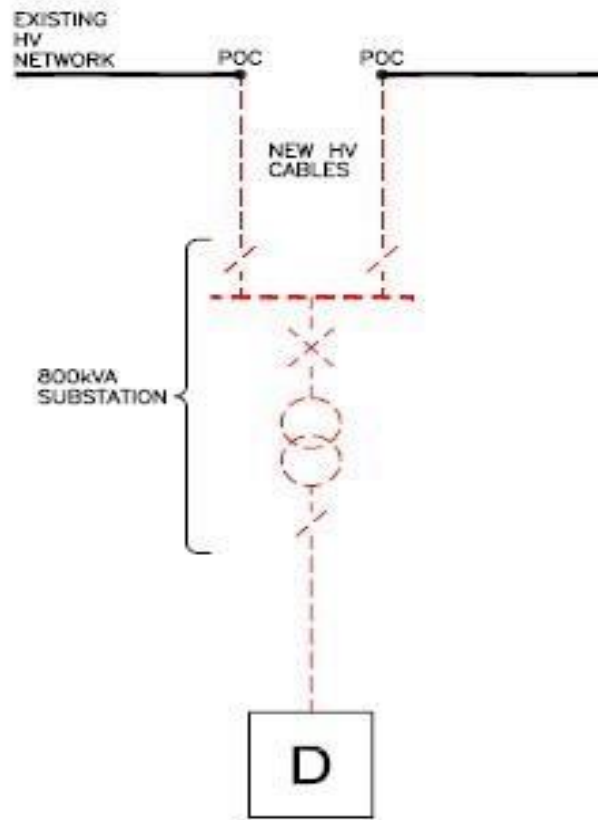

The Connection Charge for this Scheme is calculated as follows:

Extension Assets	Cost	Apportionment	Customer Contribution
Provision and installation of 300m of HV cable	£90,000	n/a	£90,000
800kVA substation	£100,000	n/a	£100,000
Provision and installation LV cabling	£6,000	n/a	£6,000
Metering panel	£4,000	n/a	£4,000
HV joints to network	£6,000	n/a	£6,000
Total Extension Asset Cost	£206,000		£206,000

Example 7: A new connection where the Minimum Scheme is as per Example 5 but the Customer requests an enhanced connection arrangement where the substation is looped into the existing HV network

In this variation to Example 5, the Customer requests an enhanced connection arrangement where the substation is looped into existing 11kV network. The Minimum Scheme is as for Example 5.

Extension Assets	Cost	Apportionment	Customer Contribution
Provision and installation of 300m of HV cable looped to network	£90,000	n/a	£90,000
800kVA substation	£100,000	n/a	£100,000
Provision and installation LV cabling	£6,000	n/a	£6,000
Metering panel	£4,000	n/a	£4,000
HV joints to network	£6,000	n/a	£6,000
Total Extension Asset Cost	£206,000		£206,000
Difference between Minimum and the actual Scheme is £73,000 (£206,000-£133,000). Operation & Maintenance @20%* of £73,000.			£14,600
Total Cost			£220,600

Example 8: A new connection where the Minimum Scheme is as per Example 5 but we request an Enhanced Scheme where the substation is looped into the existing HV network

In this variation to Example 5, the Customer is connected with a looped connection. The Minimum Scheme is as for Example 5 but we request an Enhanced Scheme where the substation is looped into the existing 11kV network.

The Connection Charge for this Scheme is calculated as follows:

Extension Assets	Cost	Apportionment	Customer Contribution
Provision and installation of 300m of HV cable looped to network	£90,000	Minimum scheme charges apply	£45,000
800kVA substation	£100,000	Minimum scheme charges apply	£85,000
Provision and installation LV Cabling	£6,000	n/a	£6,000
Metering panel	£4,000	n/a	£4,000
HV joints to network	£6,000	Minimum scheme charges apply	£6,000
Total Extension Asset Cost	£206,000		£143,000

Example 9: Additional load application for commercial premises (requiring a new connection from the HV network and Reinforcement)

A Customer requests to increase the Maximum Capacity of their existing LV connection from 200kVA to 850kVA; an increase of 650kVA (the Required Capacity). The connection is a Demand Connection.

As the Customer’s existing LV connection is unable to deliver the Required Capacity a new connection will be required from the local HV network. This will be a non- secure connection to a secure network. The Minimum Scheme is to overlay part of the nearest HV circuit (Feeder 2) which only has spare capacity of 200kVA. The Reinforcement to make the capacity available requires 1200m of existing HV cable to be overlaid with a larger capacity cable. Costs of the disconnection of the existing LV connection have not been included in this example.

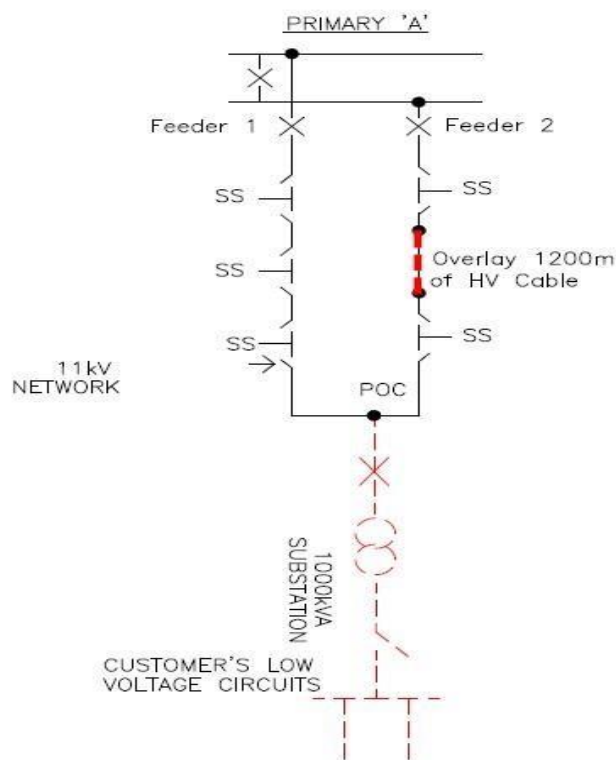

Reinforcement:

The Relevant Section of Network is the two-feeder ring comprising Feeder 1 and Feeder 2.

As this connection is a Demand Connection, the Customer will not be charged for reinforcement. The Connection Charge for this Scheme is calculated as follows:

Reinforcement Costs	Cost	Apportionment	Customer Contribution
Overlay 1200m of HV cable	£360,000	0%	£0
HV Jointing	£6,000	0%	£0
Total Reinforcement Cost	£366,000		£0

Extension Assets	Cost	Apportionment	Customer Contribution
Provision and installation HV cable	£60,000	n/a	£60,000
1000kVA substation	£80,000	n/a	£80,000
Termination of Customer's LV cables	£4,000	n/a	£4,000
LV Metering panel	£4,000	n/a	£4,000
HV Jointing	£3,000	n/a	£3,000
Total Extension Asset Cost	£151,000		£151,000

Example 10: A new connection that results in a Point of Connection further away than the nearest network

A Customer applies for a new connection with a Maximum Capacity of 100kVA. Assessment of the local network identifies that there is an existing LV cable to the front of the development, which is fed from a 315kVA transformer. The LV cable has sufficient spare capacity for the connection; however, the transformer is at full capacity and would therefore require Reinforcement work to upgrade it from a 315kVA to 500kVA transformer. Two design options are considered.

1. For the first option, the cost of this work is estimated to be £70,000, and the cost of the LV Mains Service is estimated to be £5,000.

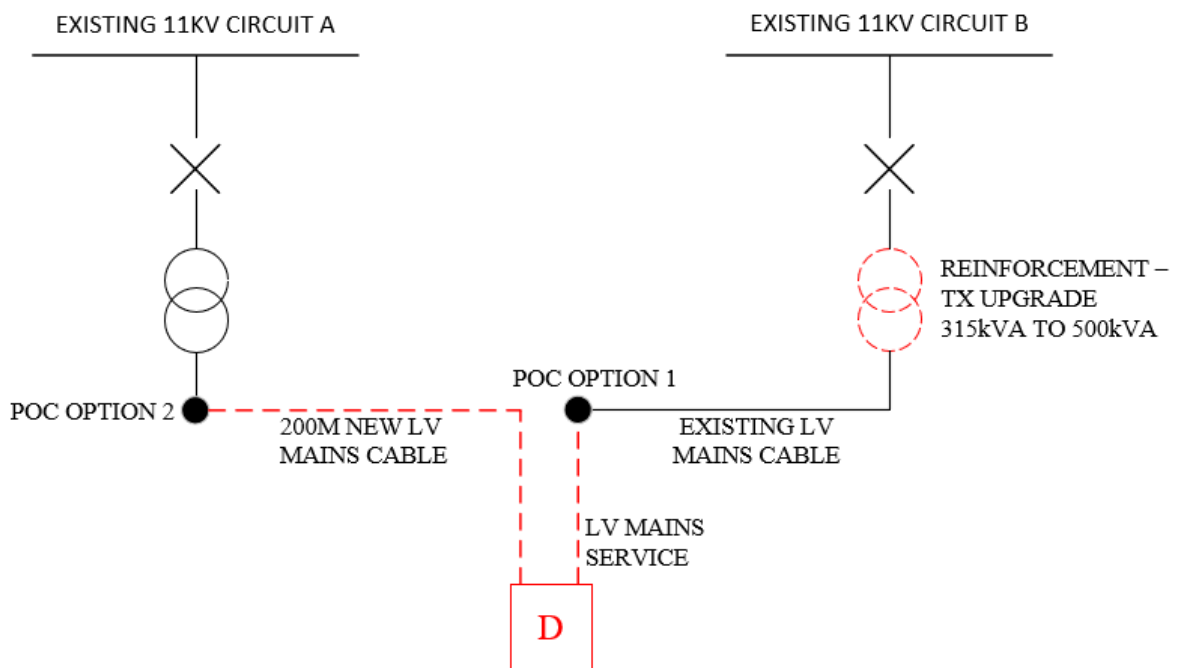

Reinforcement Costs	Cost	Apportionment	Customer Contribution
Upgrade 315kVA transformer to 500kVA	£70,000	0%	£0
Total Reinforcement Cost	£70,000		£0

Extension Assets	Cost	Apportionment	Customer Contribution
LV Mains Service	£5,000	n/a	£5,000
Total Extension Asset Cost	£5,000		£5,000

2. For the second option, there is a large cross-sectional area LV cable 200m from the development which is fed from a 1000kVA transformer, and both the LV cable and transformer have sufficient spare capacity to provide a connection to the development without Reinforcement work. This design requires Extension Assets involving 200m of LV Cable estimated to cost £40,000 and a mains type service; the cost of the LV Mains Service is £5,000 consistent with the first option.

Extension Assets	Cost	Apportionment	Customer Contribution
200m of LV mains cable	£40,000	n/a	£40,000
LV Mains Service	£5,000	n/a	£5,000
Total Extension Asset Cost	£45,000		£45,000

Option 2 has the lower overall capital cost of £45,000 (compared to £75,000 for Option 1) and therefore represents the Minimum Scheme. Whilst Option 2 results in a higher charge to the Customer, it is the overall capital cost that is used to determine the Minimum Scheme. The connection offer to the Customer would therefore be based on Option 2.

Example 11: A new Generation Connection with capacity triggered Reinforcement

A Customer requests a Generation Connection with a Required Capacity for export purposes of 3MW. The Minimum Scheme requires the Reinforcement of 500m of 11kV overhead line between points A and B to provide 7.6MVA of capacity.

The POC is to the existing 11kV network at point B and it is proposed to install 500m of 11kV underground cable from the POC to the Customer's installation and this cable is treated as Extension Assets.

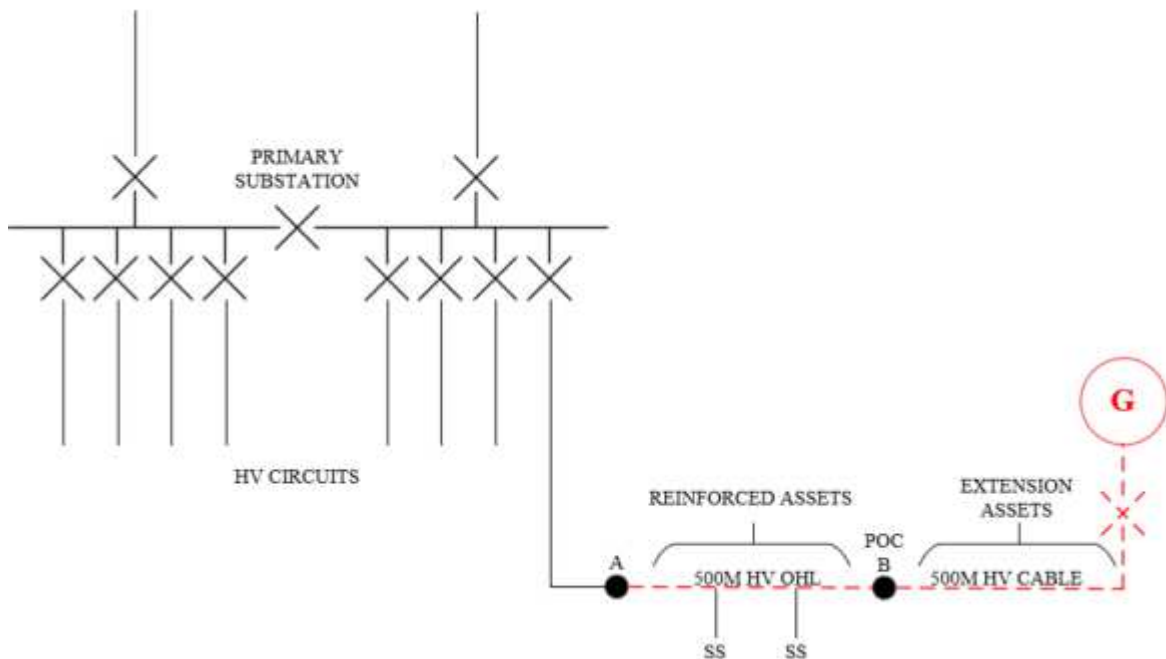

Reinforcement

The Relevant Section of Network is the 11kV OHL between points A and B and the Security CAF applies. The numerator in the CAF calculation is based upon the Required Capacity of the Customer, i.e. 3MVA and the denominator is based on the New Network Capacity following Reinforcement, i.e. 7.6MVA.

The Connection Charge for this Scheme is calculated as follows:

Reinforcement	Cost	Apportionment	Customer Contribution
Re-conductor of 500m of HV overhead line	£60,000	$3/7.6 \times 100\% = 39.5\%$ (Security CAF)	£23,700
Total Reinforcement Cost	£60,000		£23,700

Extension Assets:	Cost	Apportionment	Customer Contribution
Installation of 500m HV cable	£45,000	n/a	£45,000
HV circuit breaker at Customer's substation	£25,000	n/a	£25,000
Total Extension Asset Cost	£70,000		£70,000

Example 12: A new Generation Connection with Fault Level-Triggered Reinforcement

A Customer wishes to connect a new generator with a Required Capacity for export purposes of 6MW. The connection of the generator requires the installation of 500m of 11kV cable and 1500m of overhead line between a new circuit breaker, added to the 11kV extensible switchgear panel at an existing primary substation and a new substation at the Customer’s Premises. These assets are treated as Extension Assets.

The connection of the generator necessitates Reinforcement works to replace the 11kV switchgear at the existing primary substation with switchgear of a higher fault level rating.

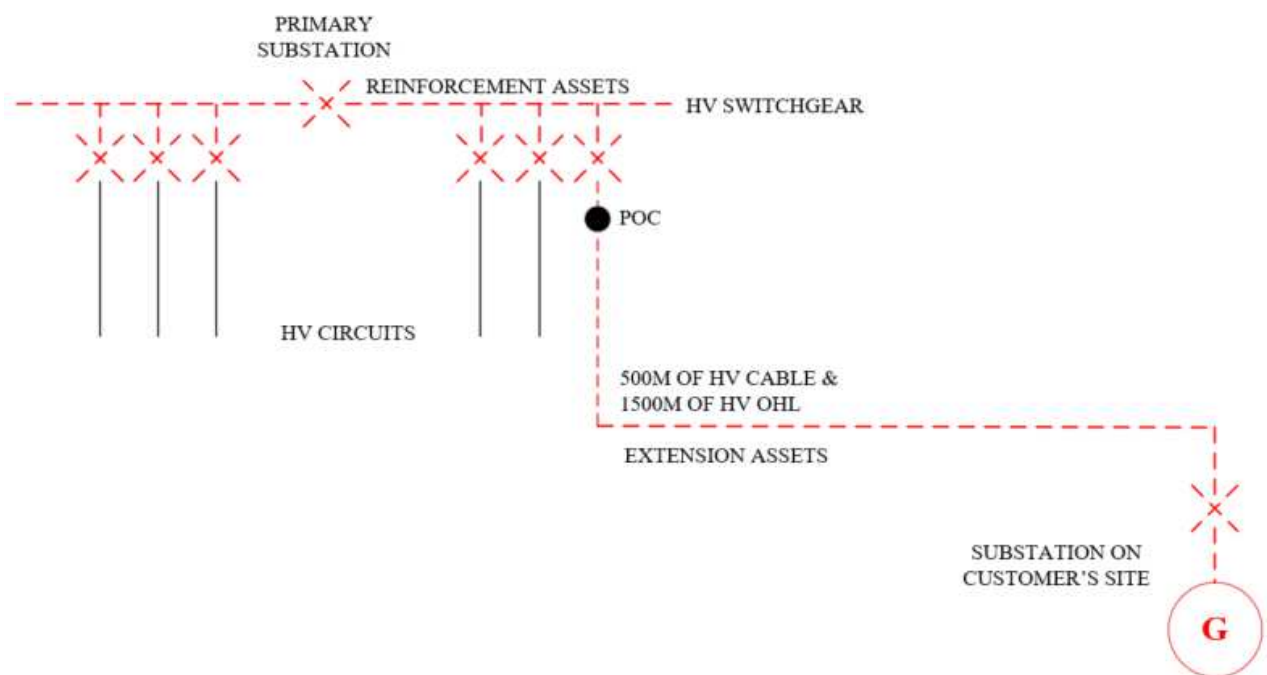

Reinforcement

Fault Level CAF calculation: The numerator in the CAF calculation is based upon the Fault Level contribution from the Customer’s new generator connection, in this example, 24MVA. The denominator is based upon the New Fault Level Capacity; in this Example the Fault Level capacity of the new 11kV switchboard, 315MVA.

The Connection Charge for this Scheme is calculated as follows:

Reinforcement	Cost	Apportionment	Customer Contribution
Replacement 11kV switchboard (excluding Customer’s sole use circuit breaker)	£800,000	$3 \times (24/315) \times 100\% = 22.9\%$ (Fault Level CAF)	£182,857
Total Reinforcement Cost	£800,000		£182,857

Extension Assets:	Cost	Apportionment	Customer Contribution
Installation of 500m HV cable	£150,000	n/a	£150,000
Installation of 1,500m HV overhead line	£120,000	n/a	£120,000
HV circuit breaker at Customer's substation	£25,000	n/a	£25,000
Total Extension Asset Cost	£325,000		£325,000

Example 13: A new Generation Connection that requires Reinforcement involving both Security and Fault Level CAFs

A Customer requests a connection to a generator with a Required Capacity for export purposes of 6MW. The Fault Level contribution at the primary substation from the generation connection is 10MVA.

The POC is to the existing 11kV network at point B and it is proposed to install 500m of 11kV underground cable from the POC to the Customer's installation. This is treated as Extension Assets.

The connection requires the Reinforcement of 500m of 11kV overhead line between points A and B for a thermal capacity requirement and the Security CAF applies. The connection also requires the replacement of the existing 11kV switchboard at the primary substation in order to increase its fault level rating from 150MVA to 350MVA and the Fault Level CAF applies. However, the new fault level will be limited by the fault level rating of the local network of 250MVA.

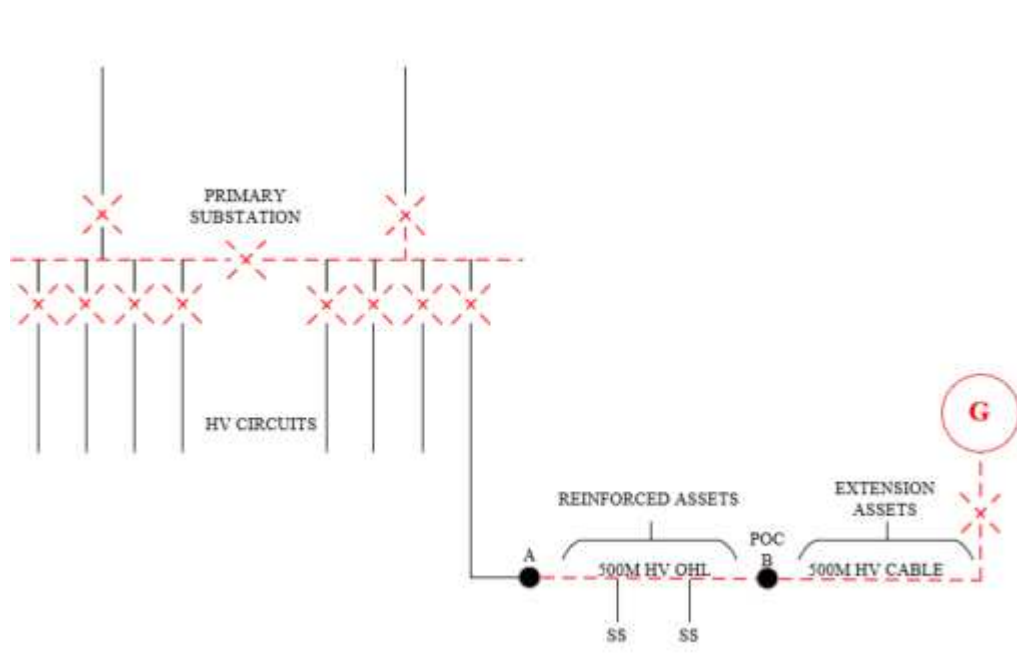

Reinforcement

The Relevant Section of Network is the 11kV network from the primary substation to Point B

Security CAF calculation: the numerator in the CAF calculation is based upon the Required Capacity of the Customer, i.e. 6MW. The denominator is based on the New Network Capacity following Reinforcement, which is 7.6MVA, i.e. after Reinforcement, in this particular case, the section of cable with the lowest rating.

The Relevant Section of Network is the 11kV switchboard at the primary substation.

Fault Level CAF calculation: The numerator in the CAF calculation is based upon the Fault Level contribution from the Customer's new generator connection, in this Example 10MVA. The denominator is based upon the New Fault Level Capacity, which is the lower of the Fault Level capacity of the new 11kV switchboard, 350MVA or of the local system, 250MVA in this Example.

The Connection Charge for this Scheme is calculated as follows:

Reinforcement	Cost	Apportionment	Customer Contribution
Re-conductor of 500m of 11kV overhead line	£20,000	$6/7.6 \times 100\% = 78.9\%$ (Security CAF)	£15,789
Replacement 11kV switchboard (excluding Customer's sole use circuit breaker)	£800,000	$3 \times (10/250) \times 100\% = 12.0\%$ (Fault Level CAF)	£96,000
Total Reinforcement Cost	£820,000		£111,789

Extension Assets:	Cost	Apportionment	Customer Contribution
Installation of 500m HV cable	£150,000	n/a	£150,000
HV pole top termination	£2,500	n/a	£2,500
HV circuit breaker at Customer's substation	£12,000	n/a	£12,000
Total Extension Asset Cost	£164,500		£164,500

Example 14: A new Generation Connection with Reinforcement at a voltage level above that of the Point of Connection

A Customer requests a Generation Connection with a Required Capacity for export purposes of 6.0MW. A new single circuit cable will be required to connect the Customer to the existing 11kV network. There is sufficient spare capacity on the existing 11kV network main but the existing 7.5MVA transformer at the local 11kV/33kV substation is fully loaded.

The Minimum Scheme is to provide a new 250m 11kV cable from the POC which is treated as Extension Assets. The connection also requires the replacement of the 7.5MW transformer at the local substation with a 10MVA transformer and is treated as Reinforcement. The 11kV and 33kV switchgear either side of the transformer also requires replacement due to exceedance of its thermal capacity.

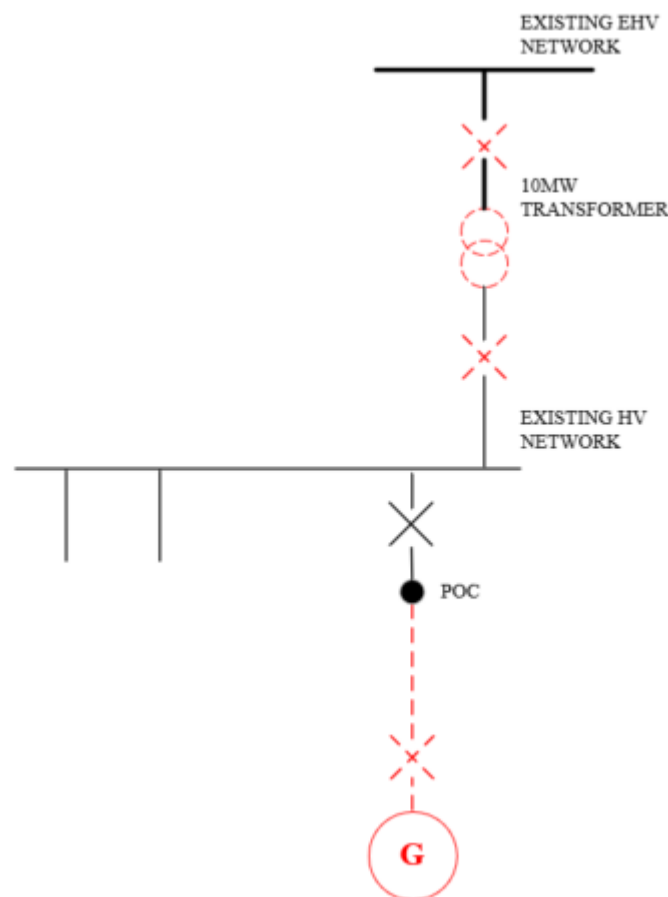

Reinforcement

Security CAF calculation: the numerator in the CAF calculation is based upon the Required Capacity of the Customer, i.e. 6MW. The denominator is based on the New Network Capacity following Reinforcement, which is 10MVA.

Reinforcement is required at both the 11kV and 33kV levels, however the CAF is only required at the same voltage of connection, which in this case is 11kV.

The Connection Charge for this Scheme is calculated as follows:

Reinforcement	Cost	Apportionment	Customer Contribution
HV Jointing	£3,000	6/10 x 100% = 60% (Security CAF)	£1,800
HV circuit breaker	£30,000	6/10 x 100% = 60% (Security CAF)	£18,000
33kV (EHV) circuit breaker	£80,000	0%	£0
Transformer replacement	£1,000,000	0%	£0
Total Reinforcement Cost	£1,113,000		£19,800

Extension Assets:	Cost	Apportionment	Customer Contribution
Installation of 200m HV cable	£60,000	n/a	£60,000
HV jointing	£3,000	n/a	£3,000
HV circuit breaker at Customer's substation	£25,000	n/a	£25,000
Total Extension Asset Cost	£88,000		£88,000

Example 15: A new Generation Connection where switchgear extension is not possible and switchgear replacement is needed.

This example demonstrates the application of Exception 4.

A Customer requests to connect a new generator with a Required Capacity for export purposes of 3MW. The connection of the generator requires the installation of the works as provided in Example 13 above. In this scenario, however, there is no Fault Level issue but, as the connection cannot be facilitated by an extension of the existing switchgear equipment in our primary substation, a full replacement of the existing switchgear installation is required. As no capacity is added to the existing shared use distribution network, the Customer will be required to fund the full cost of the switchgear installation replacement.

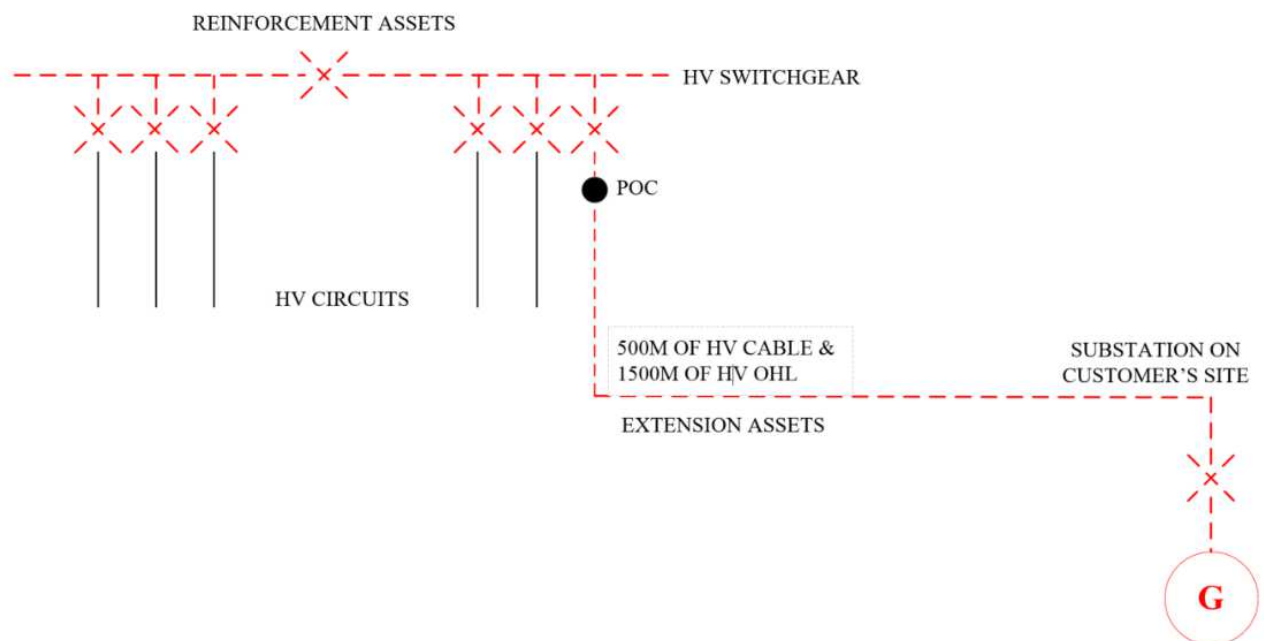

The existing switchgear had fault level rating of 250MVA. The company no longer uses switchgear with a fault level rating of 250MVA, so uses the closest equivalent switchgear used by it as standard, which has a slightly higher rating. Whilst the replacement switchgear increases the fault level capacity and could be considered Reinforcement, in this case this is due solely to the fault level rating of the standard equipment used by the company being higher than the fault level rating of the existing switchgear. The increase in fault level capacity is not required to connect the Customer. Therefore, Exception 4 (Paragraph 1.25) applies and the switchgear is considered Extension Assets and its costs will be charged in full to the Customer.

The Connection Charge for this Scheme is calculated as follows:

Reinforcement	Cost	Apportionment	Customer Contribution
Installation of a 500m 11kV cable	£150,000	n/a	£150,000
Installation of a 1,500m 11kV overhead line	£120,000	n/a	£120,000
HV circuit breaker at Customer Substation	£25,000	n/a	£25,000
Replacement 11kV switchboard	£450,000	n/a	£450,000
New Extension Asset circuit breaker	£25,000	n/a	£25,000
Total Reinforcement Cost	£770,000		£770,000

Example 16: A new Storage Connection that triggers Reinforcement.

A Customer requests to connect a Battery with a Required Capacity of 3MW export and 3MVA import. The Minimum Scheme requires the Reinforcement of 500m of 11kV overhead line between points A and B to provide 7.6MVA of capacity.

The POC is to the existing 11kV network at point B and it is proposed to install 500m of 11kV underground cable from the POC to the Customer’s installation and this cable is treated as Extension Assets.

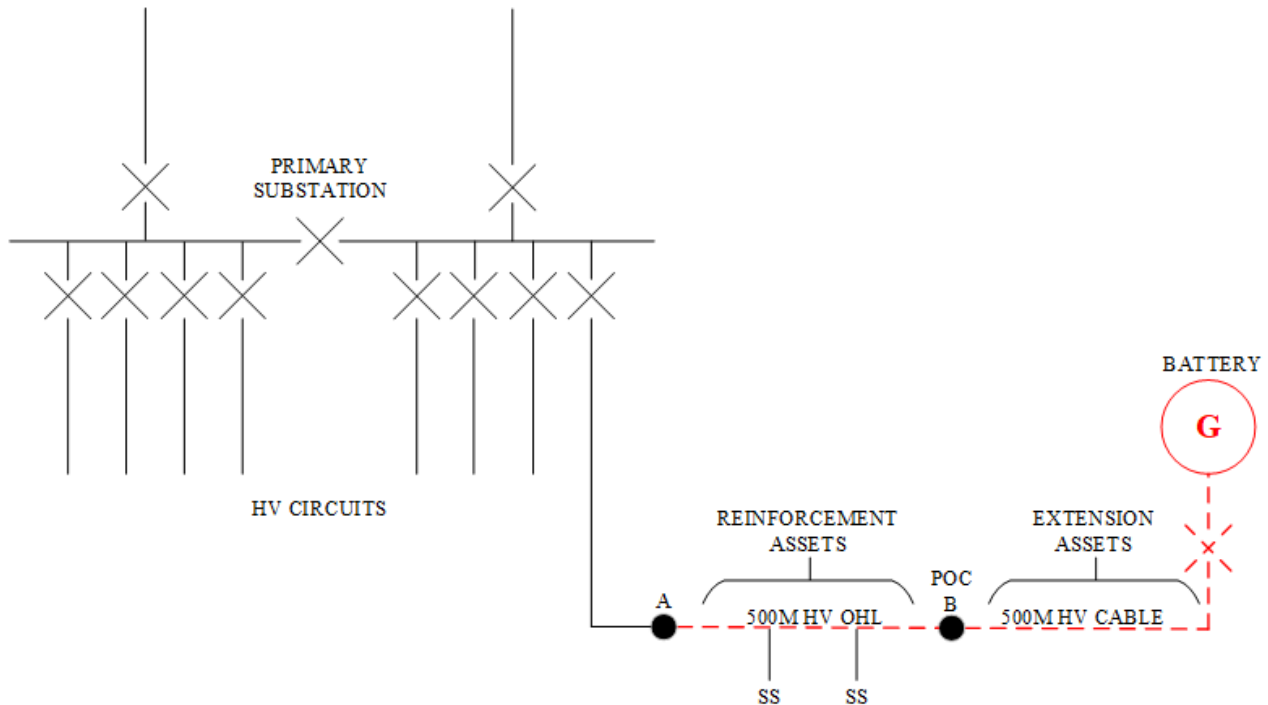

Reinforcement:

The Relevant Section of Network is the 11kV OHL between points A and B and the Security CAF applies. The numerator in the CAF calculation is based upon the Required Capacity of the Customer. In this instance, the reinforcement is driven by the Required Capacity for import, i.e. 3MVA and the denominator is based on the New Network Capacity following Reinforcement, i.e. 7.6MVA.

The Connection Charge for this Scheme is calculated as follows:

Reinforcement	Cost	Apportionment	Customer Contribution
Re-conductor 500m of 11kV overhead line at a higher capacity (7.6MVA)	£60,000	$3/7.6 \times 100\% = 39.5\%$	£23,700
Total Reinforcement Cost	£60,000		£23,700

Extension Assets	Cost	Apportionment	Customer Contribution
Installation of 500m HV cable	£45,000	n/a	£45,000
HV circuit breaker at Customer's substation	£25,000	n/a	£25,000
Total Extension Asset Cost	£70,000		£70,000

Example 17: A new connection that is connected by Reinforced assets

A new housing development has a Required Capacity of 1MVA to serve 450 plots. The local 11kV feeder has a network capacity of 7.7MVA based upon the limitation of the existing 400 Amp circuit breakers at Primary Substation A. The existing load on the circuit is 7.6MVA. The new load will be connected to the existing 11kV feeder from Primary Substation A with 100m of 11kV cable from POC A to the point D at the boundary of the site and provide interconnection with 700m of 11kV cable from POC B at Primary Substation B to the boundary of the site at point C. In this example:

- 200m of 11kV cable on site (between points C and D) is required to provide connectivity within the development and is considered to be Extension Assets.
- 100m of 11kV cable from POC A to the point D.
- 700m of 11kV cable from POC B to the point C.

The Minimum Scheme requires the site to be connected onto the existing network. In this case the lowest cost feeder is the 11kV cable from A to D and is treated as an Extension Asset. The alternative connection to POC B at Primary Substation B is required to meet the minimum network security requirements and is treated as Reinforcement.

The figure below shows the proposed network.

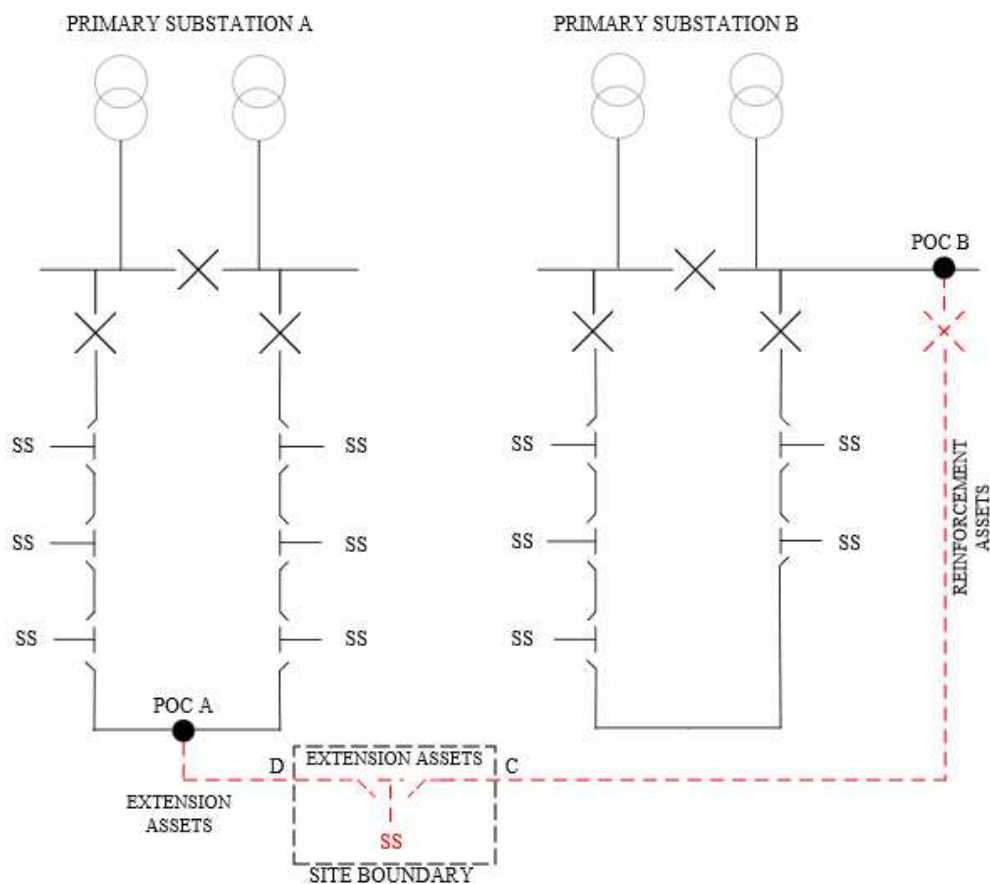

Reinforcement:

The 700m of 11kV cable from POC B at Primary Substation B to point C is treated as reinforcement however as this is a demand connection the reinforcement work is funded by us.

The Connection Charge for this Scheme is calculated as follows:

Reinforcement	Cost	Apportionment	Customer Contribution
1 new HV Circuit Breaker from POC B	£30,000	0%	£0
2 no. HV closing joints	£6,000	0%	£0
700m of HV cable from POC B to POC C	£210,000	0%	£0
Total Reinforcement Cost	£246,000		£0

Extension Assets	Cost	Apportionment	Customer Contribution
100m of HV cable from POC A to Point D	£30,000	n/a	£30,000
One 1,000kVA Substation	£75,000	n/a	£25,000
On site LV mains and services	£24,900	n/a	£24,900
2 no. HV cable box terminations	£24,000	n/a	£24,000
Total Extension Asset Cost	£153,900		£153,900

Reinforcement:

The assets connecting POC A and point C add capacity to the existing network will be treated as Reinforcement and funded by us.

The Connection Charge for this Scheme is calculated as follows:

Reinforcement	Cost	Apportionment	Customer Contribution
1 new HV Circuit Breaker tailed out from Primary Substation B	£30,000	0%	£0
2 no. HV closing joints	£6,000	0%	£0
700m of HV cable from Primary Substation B to site	£210,000	0%	£0
Total Reinforcement Cost	£246,000		£0

Extension Assets	Cost	Apportionment	Customer Contribution
600m of HV cable on site	£180,000	n/a	£180,000
3 no. 800kVA unit Substations	£225,000	n/a	£225,000
On site LV mains and services	£24,900	n/a	£24,900
2 no. HV cable box terminations	£24,000	n/a	£24,000
600m of HV cable from POC B to site	£180,000	n/a	£180,000
Total Extension Asset Cost	£633,900		£633,900

Example 19: A new connection with remote network reinforcement

This example shows the arrangements that will apply where it is necessary to reinforce a different part of the Distribution System so that existing load may be transferred in order to release capacity for the new connection.

A Customer requests a Generation Connection with a Required Capacity of 2MW. The local 11kV feeder has a network capacity of 7.7MW based upon the limitation of the existing 400 Amp circuit breakers at Primary Substation A. The existing load on the circuit is 7.7MW. It is therefore not possible to connect the new generation to this circuit without Reinforcement works.

It is proposed to reinforce an adjacent network from primary substation B so that two existing substations may be transferred on to it from primary substation A, in order to release capacity to accommodate the new connection. Primary Substation B has sufficient spare capacity to accommodate the two existing substations. A new circuit breaker is to be installed at Primary Substation B and a new 11kV feeder (also rated at 7.7MW) is to be installed between points A – B and between points E – F for connection to the local 11kV circuit at point F. The existing circuit will be cut at point BE so that the new joints can be made. This will convert the Primary Substation B network from a two-feeder to a three-feeder network. The total new cable length between points A – B and points E - F is 500m. The network will be reconfigured by the installation of two short straps C – D and G - H in order to maintain connectivity.

This Reinforcement will allow a POC to be taken from the local 11kV circuit to supply the new generation. The newly installed cable to connect the generation from the POC is 1200m long. The above work represents the Minimum Scheme to provide connections to the new site.

The figure below shows the original network.

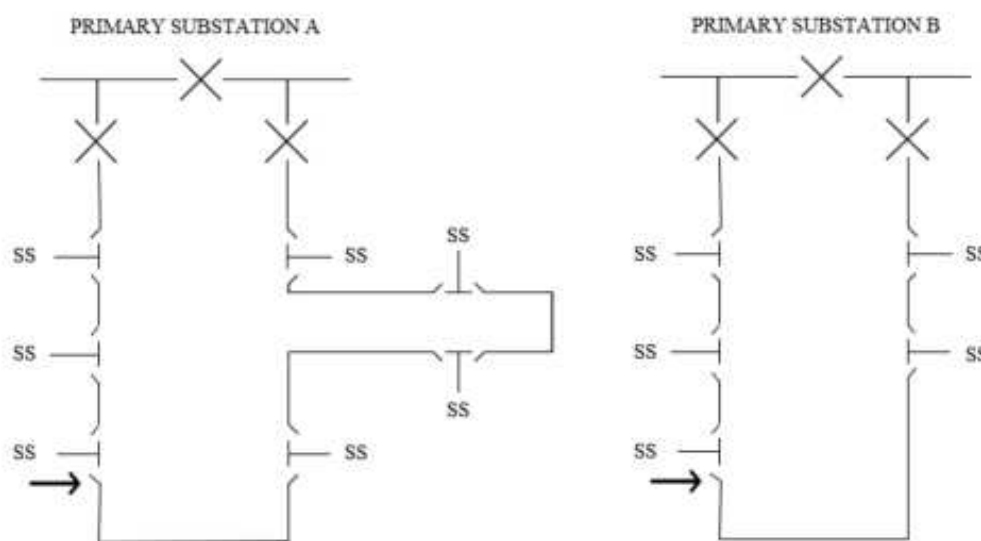

The figure below shows the proposed network.

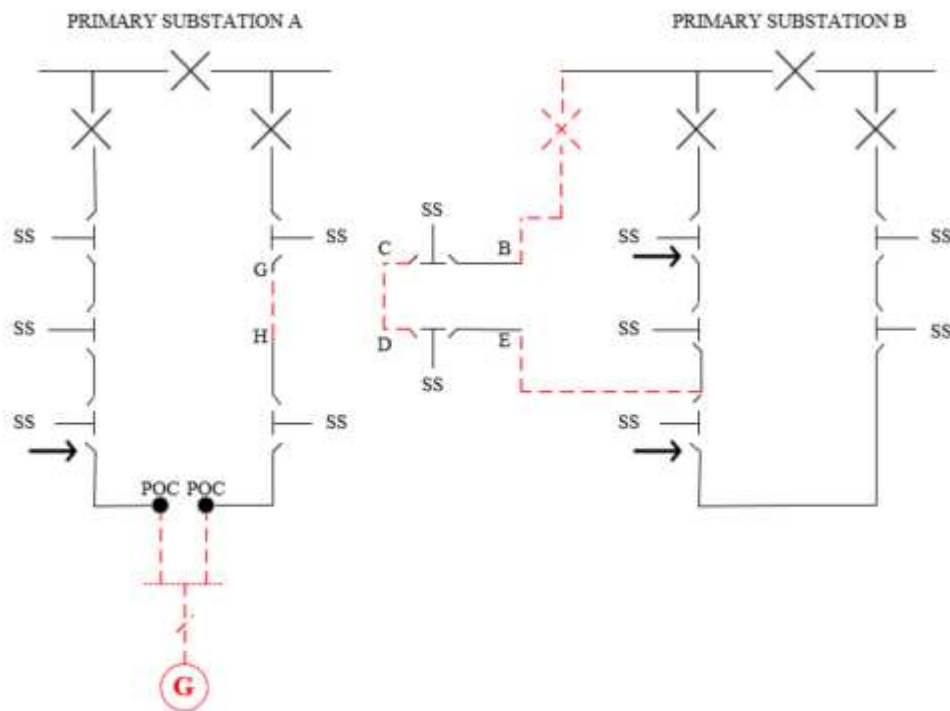

Reinforcement:

The Relevant Section of Network is the three-feeder network from Primary Substation B which supplies the loads on the existing two feeders from Primary Substation B as well as the loads at points C and D transferred from the network from the Primary Substation A. The RSN does not supply the new generation in this case. The numerator in the CAF calculation is based upon the Required Capacity of the new generation, i.e. 2MW. In this case, the New Network Capacity (under N-1 conditions) following the Reinforcement works is equal to $(3 - 1) \times 7.7\text{MW} = 15.4\text{MW}$.

Fault Level CAF calculation: This Scheme does not have any significant Fault Level contribution to the existing shared use distribution network and Fault Level CAF is therefore not applicable here.

The Connection Charge for this Scheme is calculated as follows:

Reinforcement	Cost	Apportionment	Customer Contribution
500m of HV cable: A-B, C-D, E-F	£150,000	2/15.4 X 100% = 13%	£19,480
11kV Circuit Breaker at Primary Substation B	£30,000	As above	£3,896
11kV jointing at Points A, B, C, D, E, F	£18,000	As above	£2,337
Total Reinforcement Cost	£198,000		£25,713

Extension Assets	Cost	Apportionment	Customer Contribution
1,200m of HV cable inc. strap at G-H	£360,000	n/a	£360,000
3 no. 800kVA unit Substations	£225,000	n/a	£225,000
On site LV mains and services	£24,900	n/a	£24,900
4 no. HV closing joints at POC and at points G,H	£12,000	n/a	£12,000
Total Extension Asset Cost	£621,900		£621,900

Example 20: A new connection with load transfer

This variation of Example 19 shows the arrangements that will apply where it is necessary to reconfigure the Distribution System so that existing demand may be transferred in order to release capacity for the new connection.

A new housing development has a Required Capacity of 2MVA to serve 900 plots. The local 11kV feeder has a network capacity of 7.7MVA based upon the limitation of the existing 400 Amp circuit breakers at Primary Substation A. The existing load on the circuit is 7.6MVA. It is therefore not possible to connect the new load to this circuit as presently configured.

The figure below shows the original network.

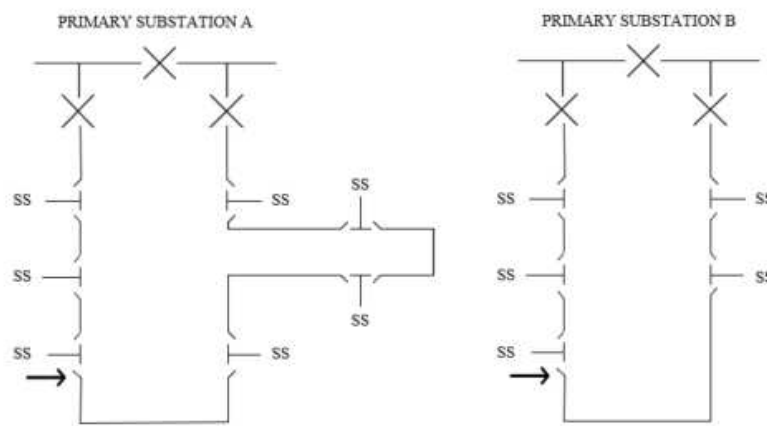

The figure below shows the proposed network.

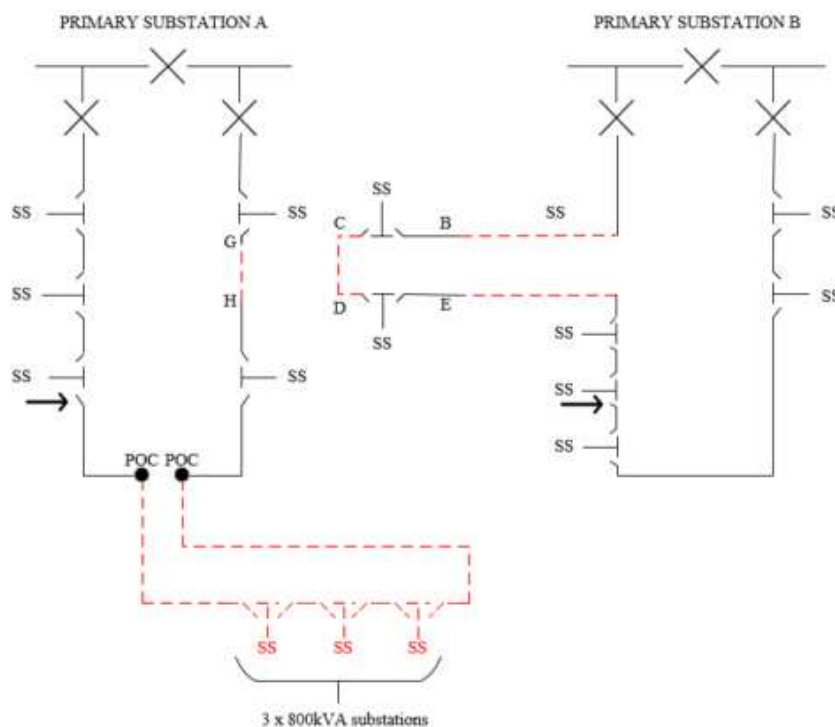

Reinforcement:

It is proposed to reconfigure the Distribution System such that two existing substations may be transferred on to an adjacent network, in order to release capacity so that the new connections can be made. Primary Substation B has sufficient spare capacity to accommodate the two existing substations. New cables are to be installed between points A – B and between points E – F. The existing circuit will be cut at point B & E so that the new joints can be made. The total new cable length between points A – B and points E - F is 100m. The network will be reconfigured by the installation of two short straps C – D and G - H in order to maintain connectivity. As this work involves the transfer of capacity there is no Reinforcement work required.

This transfer of existing demand will allow a POC to be taken from the local 11kV circuit to connect the new development. The newly installed cable to connect the development from the POC is 1,200m long. Three 800kVA distribution substations are to be established onsite. The above work represents the Minimum Scheme to provide connections to the new site.

The Connection Charge for this Scheme is calculated as follows:

Extension Assets	Cost	Apportionment	Customer Contribution
1,300m of HV cable including A-B, C-D, E-F, G-H and from POC to the development	£390,000	n/a	£390,000
3 no. 800kVA unit Substations	£225,000	n/a	£225,000
On site LV mains and services	£24,900	n/a	£24,900
2 no. HV closing joints at POC and at points A, B, C, D, E, F, G, H	£30,000	n/a	£30,000
Total Extension Asset Cost	£669,900		£669,900

Example 21: A new Generation Connection with an Enhanced Scheme at the DNO's request

Please refer to Example 11, which is the Minimum Scheme for this project. In this example, a Customer requests a Generation Connection with a Required Capacity for export purposes of 3MW. The Minimum Scheme requires the Reinforcement of 500m of 11kV overhead line between points A and B to provide 7.6MVA of capacity. However, the DNO has decided to install an Enhanced Scheme by increasing the capacity of the 11kV overhead line to 13MVA.

The POC is to the existing 11kV network at point B and it is proposed to install 500m of 11kV underground cable from the POC to the Customer's installation.

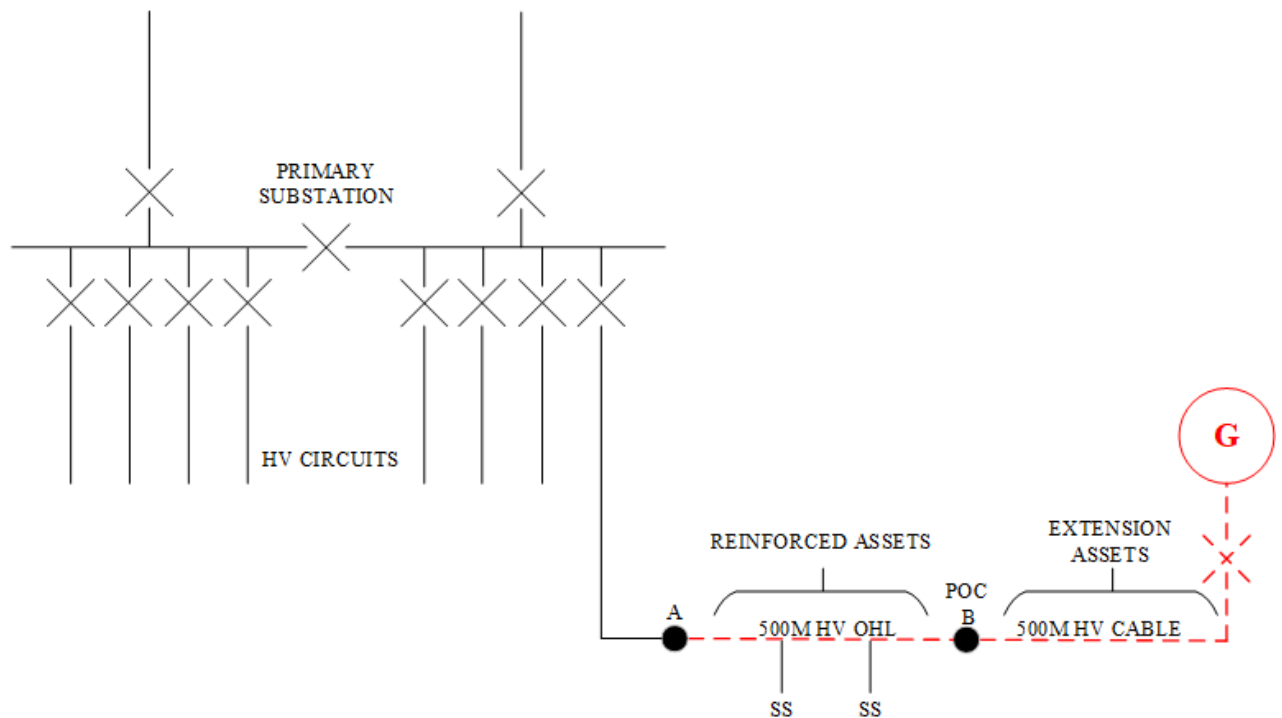

Reinforcement:

The Relevant Section of Network is the 11kV OHL between points A and B

Security CAF calculation: The numerator in the CAF calculation is based upon the Required Capacity of the new generation, i.e. 3MW. In this example the DNO has decided to install an Enhanced Scheme and the Connection Charge that will apply will be the lower of the Connection Charge associated with the Minimum Scheme (see Example 11) and the Enhanced Scheme. The numerator in the CAF calculation is based upon the Required Capacity of the Customer, i.e. 3MW and the denominator is based on the Enhanced Scheme New Network Capacity following Reinforcement, i.e. 13MVA.

Fault Level CAF calculation: This Scheme does not have any significant Fault Level contribution to the existing shared use distribution network so the Fault Level CAF is therefore not applicable here.

The Connection Charge for this Scheme is calculated as follows:

Reinforcement	Cost	Apportionment	Customer Contribution
Reconductor 500m of HV overhead line at a higher capacity (13MVA)	£70,000	$3/13 \times 100\% = 23.1\%$	£16,170
Total Reinforcement Cost	£70,000		£16,170

Extension Assets	Cost	Apportionment	Customer Contribution
1,200m of HV cable inc. strap at G-H	£45,000	n/a	£45,000
3 no. 800kVA unit Substations	£25,000	n/a	£25,000
Total Extension Asset Cost	£70,000		£70,000

Example 22: A new Generation Connection on a meshed HV distribution system requiring Reinforcement

A Customer requests a new Generation Connection requiring a 4MVA 11kV metered connection. The local 11kV network is of a meshed design whereby the 11kV network is supplied from single 33/11kV primary transformers via 33kV radial feeds as shown below.

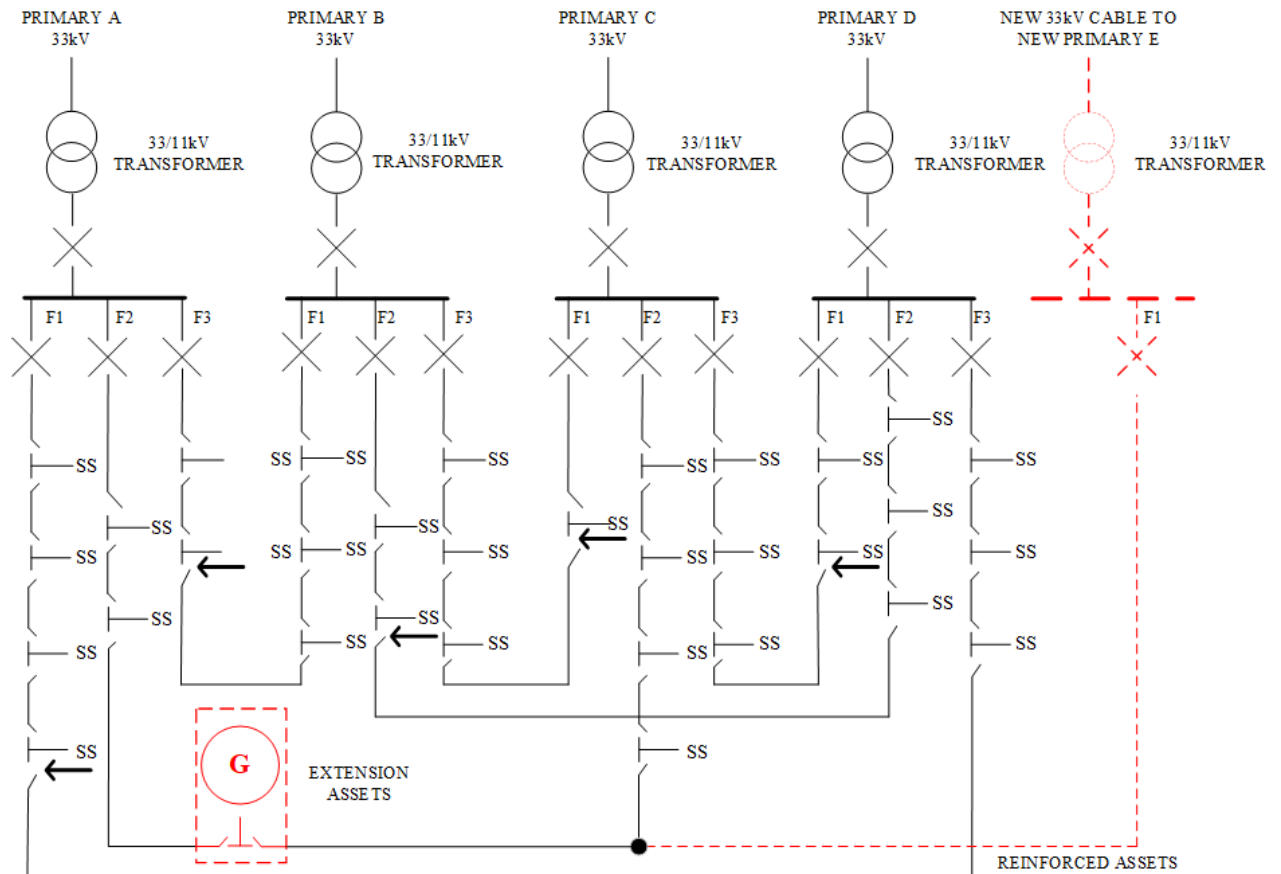

The existing network consists of four 10MVA primary transformer substations and associated 11kV switchgear. A new connection of 4MVA has been requested in the vicinity of F2 from Primary A.

The existing relevant primary transformer group is loaded to its secure capacity so the primary transformer group will require Reinforcement to enable the new connection to progress.

To provide the Required Capacity, the 11kV network will be reinforced by the installation of a new primary substation connected to the nearest 33kV circuit. The new primary substation (Primary E) will contain a 10MVA transformer, associated 11kV switchgear and a new 11kV (7.7 MVA) cable installed to interconnect into the existing 11kV network (from F2 at Primary A to F2 at Primary C).

Reinforcement:

Security CAF calculation: In this example there are two different Security CAFs applied. This is because the Relevant Section of Network is different when considering the New Network Capacity in respect of different elements of the Reinforcement works.

The Relevant Section of Network for the Reinforcement comprising the 11kV Cable Works:

For the 11kV cable assets the Relevant Section of Network is considered to be the secure three feeder 11kV network from Primary A (Feeder 2), Primary C (Feeder 2) and Primary E (Feeder 1). In this case the New Network Capacity (under secure N -1 conditions) following the Reinforcement works is equal to

$$(3 - 1) \times 7.7\text{MVA} = 15.4\text{MVA}$$

This is due to the fact that following the Reinforcement work both of the existing circuits; Primary A, Feeder 2 and Primary C, Feeder 2 can be loaded to their full capacity and will have the newly installed clean feeder from Primary E to act as a back feed to meet the requirements of P2.

The Security CAF for these assets will therefore be $4/15.4 \times 100\% = 26.0\%$

The Relevant Section of Network for the Reinforcement comprising the Primary substation assets:

In this instance the Relevant Section of Network comprises Primary A, C and E within the group that can be used to supply the Customer in normal and abnormal conditions. The New Network Capacity of this Relevant Section of Network (under secure N -1 conditions) following the Reinforcement works is equal to 17.7MVA. (10MVA from either Primary A or Primary C and 7.7MVA from Primary E which is limited by the single 11kV cable connected to it.

The Security CAF for these assets will therefore be $4/17.7 \times 100\% = 22.6\%$ towards the 11kV assets to be installed.

Due to the voltage rule, contributions will not be required towards the 33kV assets.

Fault Level CAF calculation: This Scheme does not have any significant Fault Level contribution to the existing shared use distribution network and Fault Level CAF is therefore not applicable here.

The Connection Charge for this Scheme is calculated as follows:

Reinforcement	Cost	Apportionment	Customer Contribution
500m of HV cable from new primary substation E	£150,000	4/15.4 X 100% = 26.0%	£39,000
1 by 11kV closing joints	£3,000	As above	£780
11kV switchgear at new Primary E	£30,000	4/17.7 X 100% = 22.6%	£6,780
Primary transformer	£6,500,000	0%	£0
2.5km of 33kV cable installation	£1,000,000	0%	£0
33kV Circuit Breaker	£80,000	0%	£0
33kV Termination	£30,000	0%	£0
Total Reinforcement Cost	£7,793,000		£46,560

Extension Assets	Cost	Apportionment	Customer Contribution
11kV ring main unit	£25,000	n/a	£25,000
11kV metering unit	£12,000	n/a	£12,000
500m of 11kV cable	£150,000	n/a	£150,000
2 by 11kV closing joints	£6,000	n/a	£6,000
Total Extension Asset Cost	£193,000		£193,000

Example 23: A non-secure Generation Connection with non-secure Reinforcement.

A Customer wishes to connect a new generator (a Generation Connection) with a Required Capacity for export purposes of 5 MVA. The connection of the generator requires the installation of 1,000m of 33kV cable and a 33kV metering circuit breaker, these being Extension Assets. An existing spare circuit breaker at the substation is utilised which, in this case, is not chargeable to the Customer.

As there is insufficient capacity in the existing 24.0 MVA thermal capacity rated 33kV feeder for the new generation due to the presence of existing generation, the connection also requires the installation of a new 33kV feeder, which also has a thermal capacity of 24.0 MVA, as Reinforcement. This is the Minimum Scheme as it is cheaper to do this, to the extent as shown in the diagram below, rather than upgrade the existing 33kV feeder to the same point along it.

Reinforcement:

The numerator in the CAF calculation is the Required Capacity of the new generator, which is 5.0 MVA.

The RSN in this case is the existing 33kV feeder and the new 33kV feeder. The New Network Capacity is calculated using the non-secure capacity and is therefore the sum of the thermal capacities of the two feeders, which is 48.0 MVA. This is the denominator in the CAF calculation.

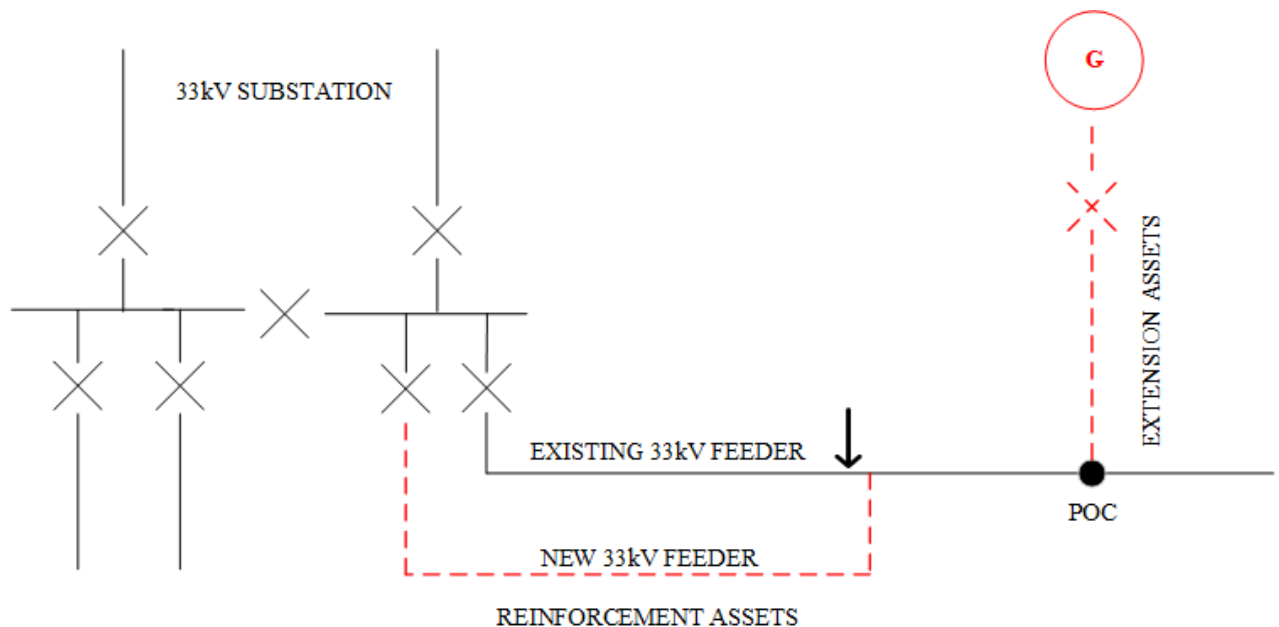

The Connection Charge for this Scheme is calculated as follows:

Reinforcement	Cost	Apportionment	Customer Contribution
Installation of a new 33kV feeder	£500,000	$5.0 / 48.0 \times 100\% = 10.4\%$	£52,000
Total Reinforcement Cost	£500,000		£52,000

Extension Assets	Cost	Apportionment	Customer Contribution
Installation of 1,000m 33kV cable	£400,000	n/a	£400,000
Installation of 33kV metering circuit breaker	£80,000	n/a	£80,000
11kV Jointing x2	£6,000	n/a	£6,000
Total Extension Asset Cost	£486,000		£486,000

Example 24: A non-secure Generation Connection with secure Reinforcement.

A Customer applies for a new generator (a Generation Connection) requiring an 8 MW metered connection. In this case, the Customer has exercised their option to request non-secure Extension Assets in the provision of the connection.

The existing network comprises a substation which has 2 x 15 MVA 33/11kV transformers. The Minimum Scheme to provide the connection is to install 750m of 11kV cable from the substation to the industrial premises, as Extension Assets. As there is insufficient capacity available from the existing 2 x 15 MVA transformers to provide the new connection, it will be necessary to upgrade the transformers to 2 x 24 MVA units along with their associated 11kV circuit breakers. The Reinforcement is required to ensure the 11kV network load can be maintained during planned or unplanned outages of one of the transformers. Although the Customer wishes to accept a non-secure connection, the substation must provide secure capacity to its Group Demand (which includes the Customer) to comply with the requirements of Engineering Recommendation P2. As the Extension Assets will be provided solely for the Customer, these can be provided on the basis of a single circuit to provide a non-secure connection, at the Customer's request.

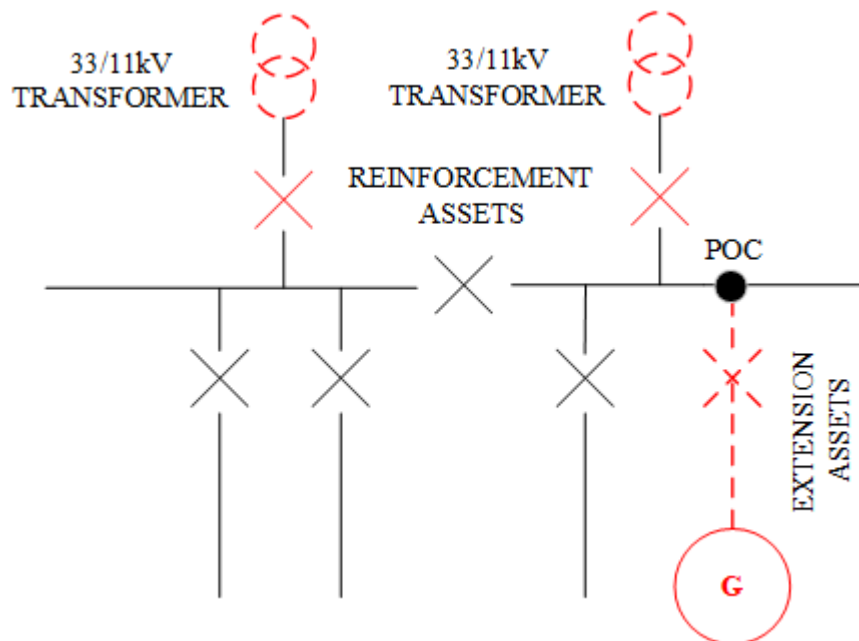

Reinforcement:

As the transformer Reinforcement is a voltage above, the generator will not contribute towards this part of the works.

The numerator in the CAF calculation is the Required Capacity, which is 8.0 MVA.

The New Network Capacity is the secure capacity of the transformers, which is 24 MVA. This is the denominator in the CAF calculation.

The Connection Charge for this Scheme is calculated as follows:

Reinforcement	Cost	Apportionment	Customer Contribution
Installation of 2 x 24MVA 33/11kV transformers	£6,500,000	0%	£0
2 x 11kV circuit breakers	£60,000	$8 / 24 \times 100\% = 33.3\%$	£20,000
Total Reinforcement Cost	£6,560,000		£20,000

Extension Assets	Cost	Apportionment	Customer Contribution
750m of HV cable	£225,000	n/a	£225,000
HV metering circuit breaker	£30,000	n/a	£30,000
11kV Jointing x2	£6,000	n/a	£6,000
Total Extension Asset Cost	£261,000		£261,000

Example 25: A new Generation Connection with voltage rise triggered Reinforcement.

A Customer wishes to connect a new generator (a Generation Connection) with a Required Capacity for export purposes of 2MVA.

The local 11kV feeder has a large amount of generation already connected and will need to be reinforced in order to keep voltage rise within acceptable limits.

The Minimum Scheme requires Reinforcement of the existing 185mm² 11kV underground cable with 300mm² underground cable and installation of a new substation for connection of the 2MW export capacity. The total length of the reinforced cable is 2km. The thermal rating of the 300mm² underground cable is 8MVA. The 11kV underground cable on the other side of the normal open point is already 300mm² and does not require to be reinforced.

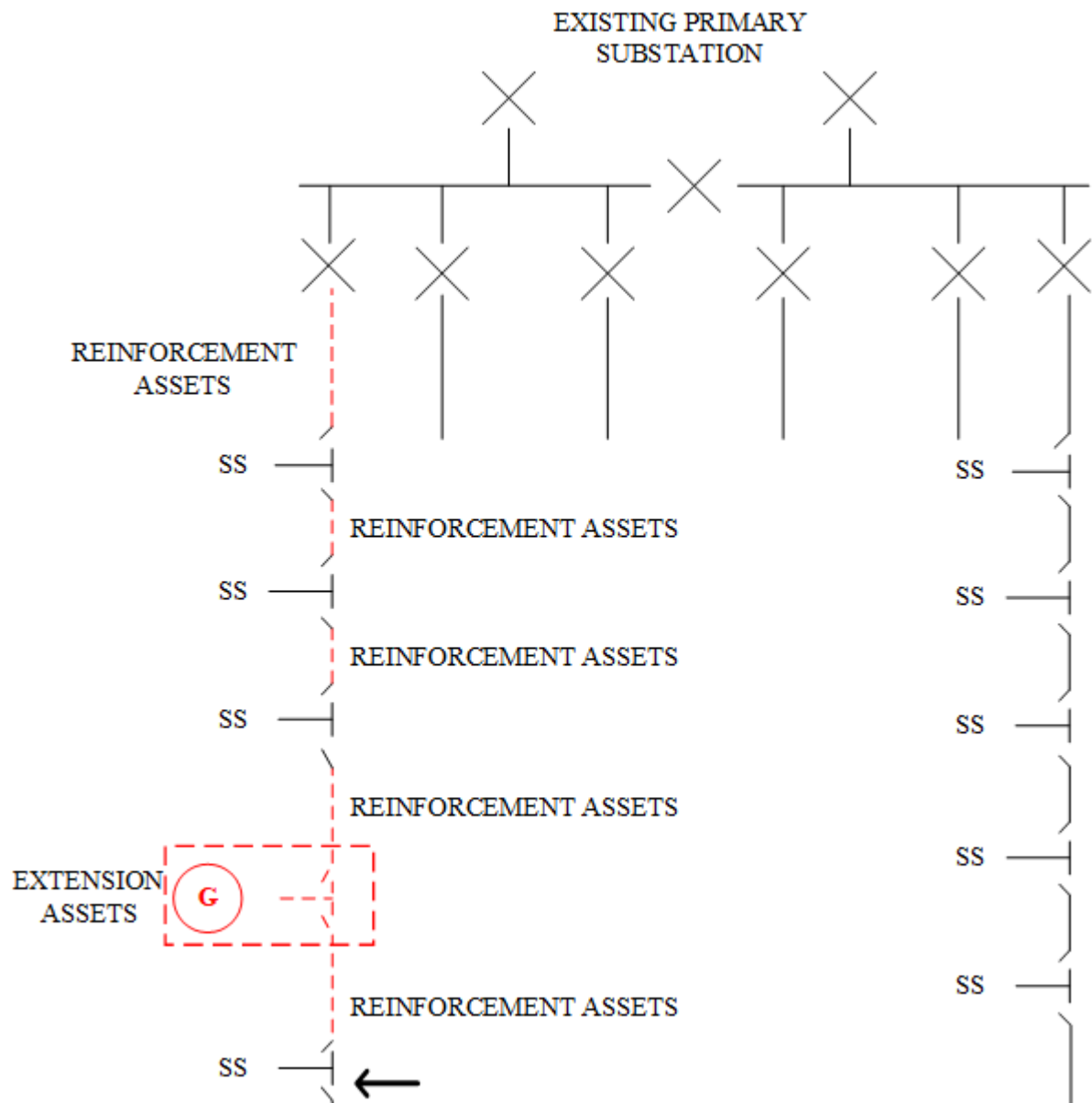

Reinforcement:

The Relevant Section of Network for the Reinforcement is the 11kV feeder.

Security CAF calculation: the numerator in the CAF calculation is the Required Capacity of the Customer, i.e. 2MW. The denominator is the New Network Capacity following Reinforcement, this being the maximum generation that could be connected whilst keeping the voltage rise within acceptable limits, i.e. 8MVA in this case.

Fault Level CAF calculation: this scheme does not have any significant Fault Level contribution to the existing shared use distribution network and Fault Level CAF is therefore not applicable here.

The Connection Charge for this Scheme is calculated as follows:

Reinforcement	Cost	Apportionment	Customer Contribution
2km 300mm ² HV cable	£600,000	2 / 8 x 100% = 25%	£150,000
Total Reinforcement Cost	£600,000		£150,000

Extension Assets	Cost	Apportionment	Customer Contribution
2MVA 11kV Substation	£160,000	n/a	£160,000
2 by 11kV Closing Joints	£6,000	n/a	£6,000
Total Extension Asset Cost	£166,000		£166,000

Example 26: A new Generation Connection with voltage rise triggered Reinforcement.

A Customer wishes to connect a new generator (a Generation Connection) with a Required Capacity for export of 250kW. The Minimum Scheme for connection of the generator requires the local 11kV overhead line to be reinforced with 100mm² conductor over part of its length in order to keep voltage rise within acceptable limits. The thermal capacity of the 100mm² overhead line is 5MVA. The thermal capacity of the original 50mm² overhead line is 3MVA. A new 315kVA ground mounted substation requires to be installed at the premises. The overhead line is 1km in length but only 500m is required to be reinforced in order to keep voltage rise within acceptable limits.

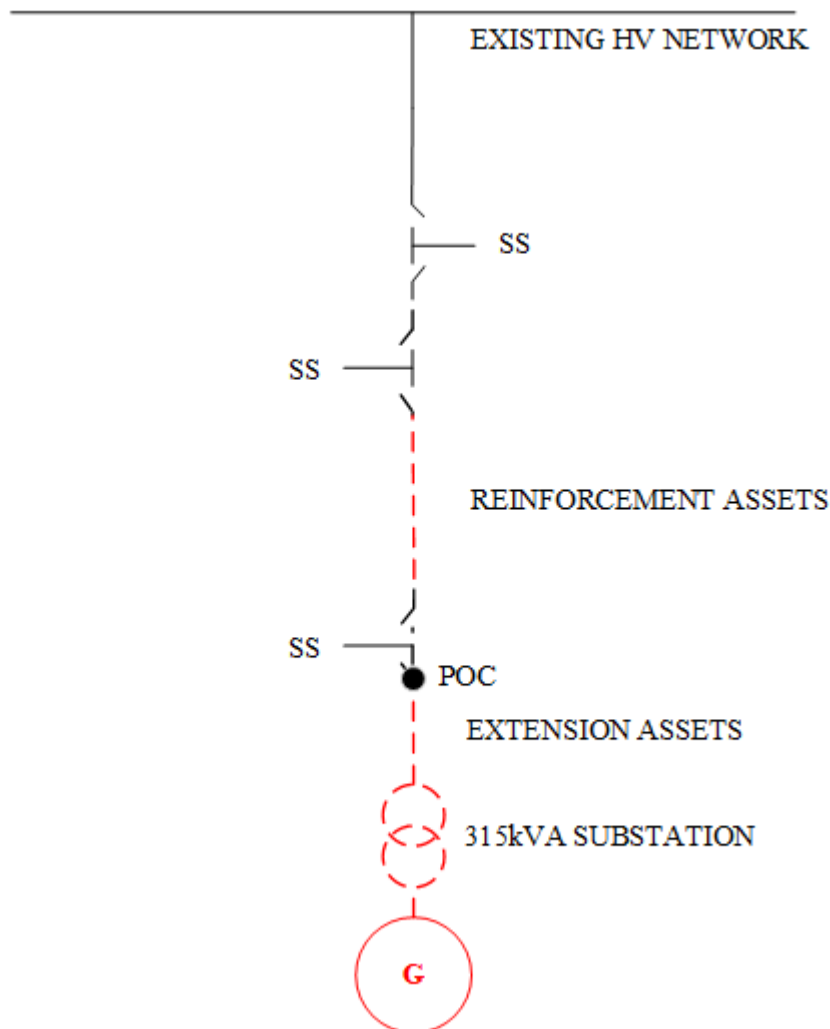

Reinforcement:

The Relevant Section of Network for the Reinforcement is the 11kV overhead line.

Security CAF calculation: the numerator in the CAF calculation is the Required Capacity of the Customer, i.e. 250kW. The denominator is the New Network Capacity following Reinforcement, this being the maximum generation that could be connected whilst keeping the voltage rise within acceptable limits. As the length of overhead line to be

reinforced has been determined to accommodate the 250kW requirement only, then this is also 250kW in this case.

Fault Level CAF calculation: this scheme does not have any significant Fault Level contribution to the existing shared use distribution network and Fault Level CAF is therefore not applicable here.

The Connection Charge for this Scheme is calculated as follows:

Reinforcement	Cost	Apportionment	Customer Contribution
Replacement 11kV overhead line conductor	£40,000	$250 / 250 \times 100\% = 100\%$	£40,000
Total Reinforcement Cost	£40,000		£40,000

Extension Assets	Cost	Apportionment	Customer Contribution
Provision and installation of 315kV substation	£60,000	n/a	£60,000
11kV joint to network	£3,000	n/a	£3,000
Total Extension Asset Cost	£63,000		£63,000

Example 27: A new Generation Connection with fault level triggered Reinforcement and transmission works.

A Customer requests a 65MW connection for a new 132kV generator (a Generation Connection) and the 85MVA Fault Level contribution from the generator necessitates Reinforcement works to replace the 132kV switchgear at the existing grid supply point with switchgear of a higher fault level rating. The Fault Level contribution also requires upgrades to the transmission system to replace the 132kV transformer tails and associated switchgear. New 132kV Extension Assets from the existing 132kV system will be required to connect the generator.

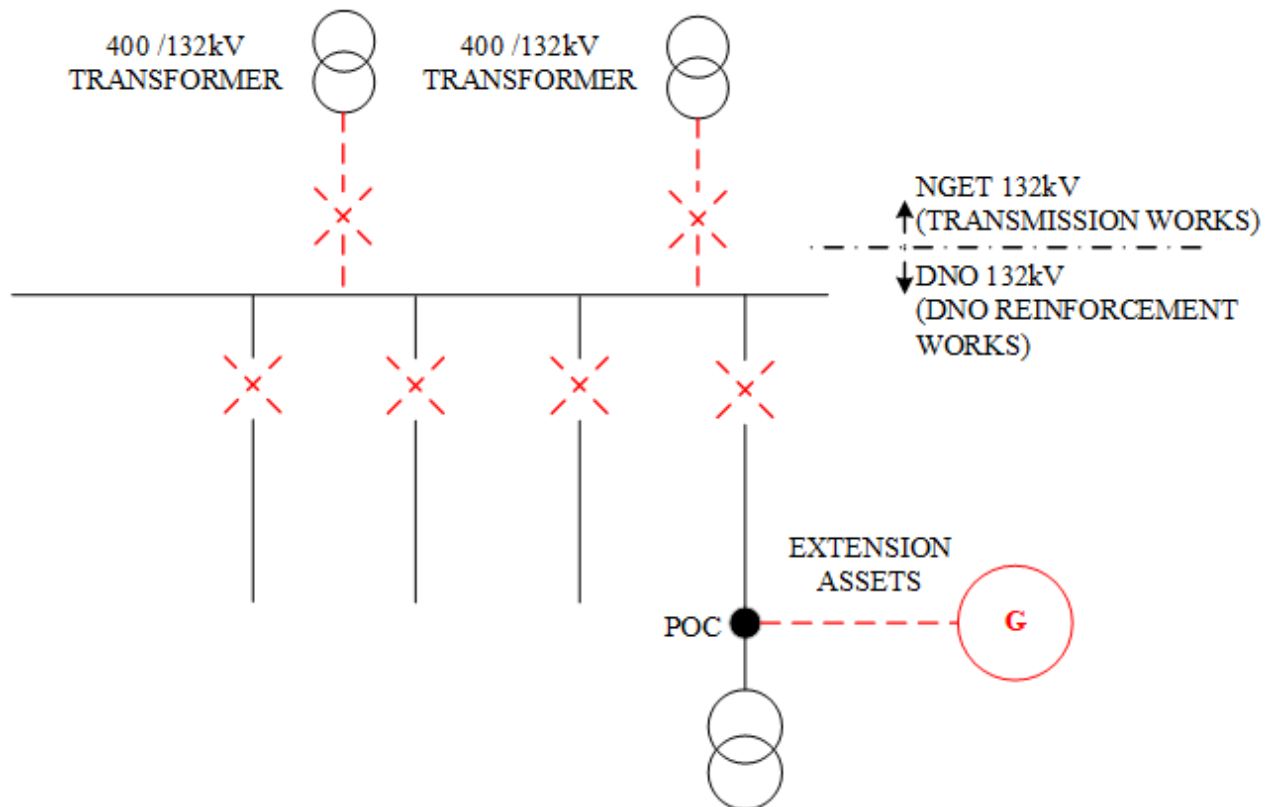

Reinforcement:

In this example the Reinforcement is at the voltage level of the POC and the Fault Level CAF is applied to the DNO works only.

Fault Level CAF calculation: The numerator in the CAF calculation is based upon the Fault Level contribution from the Customer’s new generator connection, i.e. 85MVA. The denominator is based upon the New Fault Level Capacity, in this Example the Fault Level capacity of the new 132kV switchgear, i.e. 9,140MVA.

Transmission:

The cost of the transmission works is fully funded by the Customer.

The Connection Charge for this Scheme is calculated as follows:

Transmission Works	Cost	Apportionment	Customer Contribution
Replace the 132kV transformer tails and associated switchgear	£5,000,000	N/A	£5,000,000
Total Reinforcement Cost	£5,000,000		£5,000,000

Reinforcement	Cost	Apportionment	Customer Contribution
Reinforcement: replace the existing 132kV switchgear	£10,000,000	3 x (85/9140) x 100% = 2.8%	£280,000
Total Reinforcement Cost	£10,000,000		£280,000

Extension Assets	Cost	Apportionment	Customer Contribution
Installation of 200m 132kV underground cable	£400,000	N/A	£400,000
Total Extension Asset Cost	£400,000		£400,000

Example 28: A new Generation Connection with fault level triggered Reinforcement and transmission works.

A Customer requests a 50MW connection for a new 33kV generator (a Generation Connection) and the 75MVA Fault Level contribution from the generator necessitates Reinforcement works to replace the 132kV switchgear at the existing grid supply point with switchgear of a higher fault level rating. The Fault Level contribution also requires upgrades to the transmission system to replace the 132kV transformer tails and associated switchgear. New 33kV Extension Assets from the existing 33kV system will be required to connect the generator.

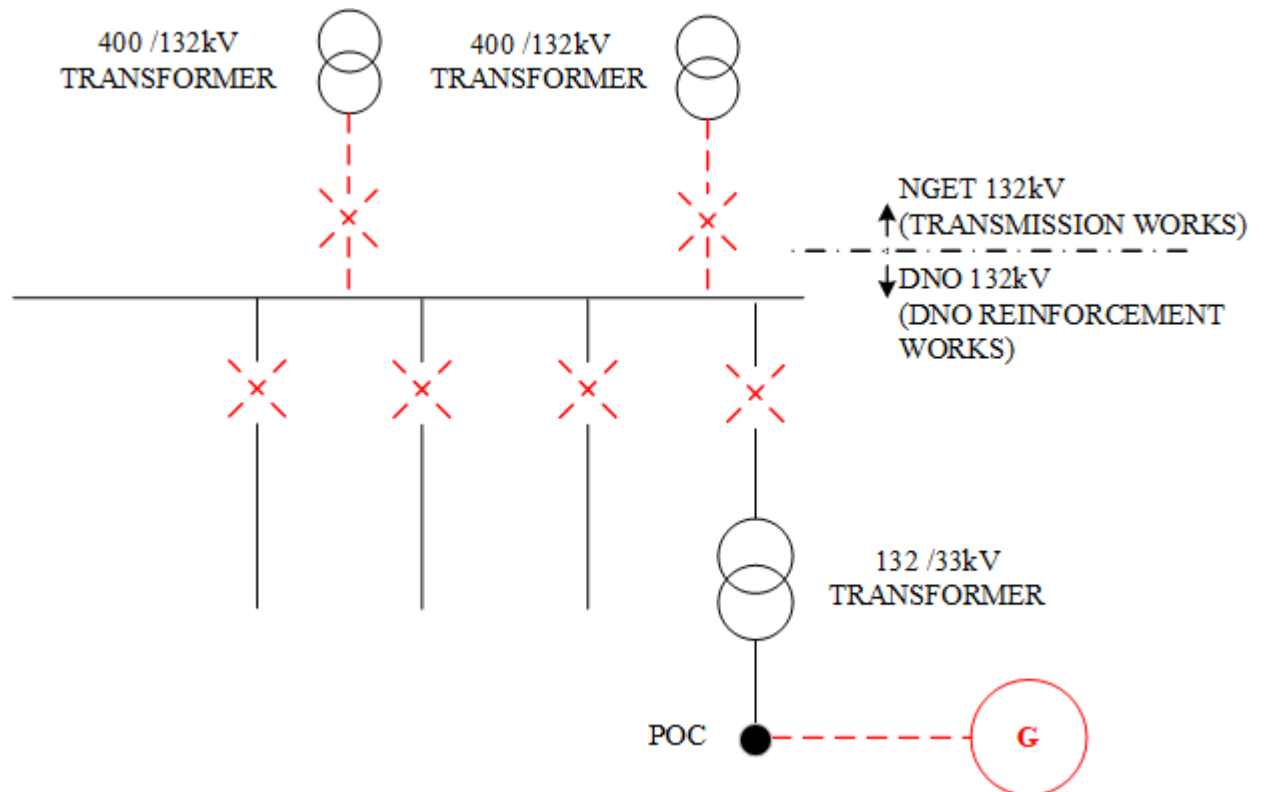

Reinforcement:

In this example the Reinforcement is at the voltage level above the POC and fully funded by the DNO.

Transmission:

The cost of the transmission works is fully funded by the Customer.

The Connection Charge for this Scheme is calculated as follows:

Transmission Works	Cost	Apportionment	Customer Contribution
Replace the 132kV transformer tails and associated switchgear	£5,000,000	N/A	£5,000,000
Total Reinforcement Cost	£5,000,000		£5,000,000

Reinforcement	Cost	Apportionment	Customer Contribution
Replacement 132kV switchboard (excluding Customer's sole use circuit breaker)	£10,000,000	N/A	£0
Total Reinforcement Cost	£10,000,000		£0

Extension Assets	Cost	Apportionment	Customer Contribution
Installation of a 500m 33kV cable	£40,000	N/A	£40,000
33kV circuit breaker at Customer substation	£25,000	N/A	£25,000
Total Extension Asset Cost	£75,000		£75,000

Example 29: A new Demand Connection that has Reinforcement above the High-Cost Project Threshold.

A Customer wishes to connect a new supply to a commercial premise for 70kVA (the Required Capacity). This will be a non-secure Demand Connection to a secure network.

The Minimum Scheme is to overlay part of the nearest 11kV circuit (Feeder 2) which only has spare capacity of 50kVA. The Reinforcement to make the capacity available requires 1200m of existing 11kV cable to be overlaid with a larger capacity cable.

Following the Reinforcement the New Network Capacity will be 8000kVA. (i.e. after Reinforcement, in this particular case, the section of cable with the lowest rating in the ring represented by Feeder 1 and Feeder 2 is rated at 8000kVA).

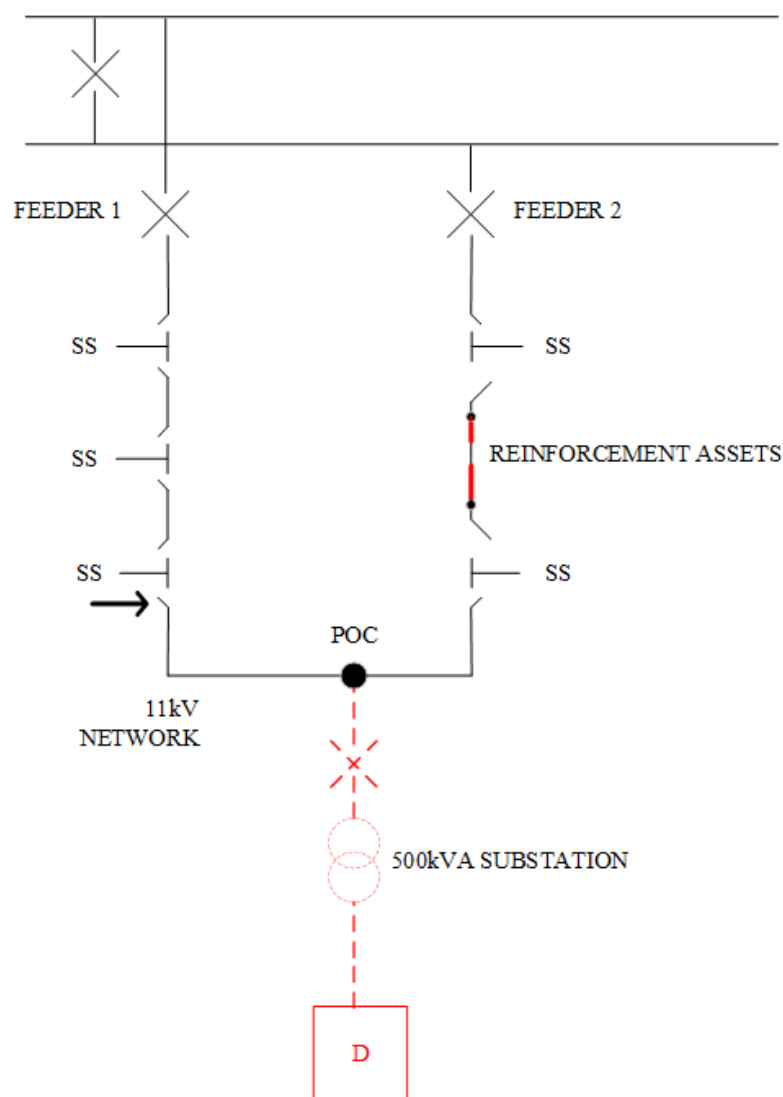

Reinforcement:

The Relevant Section of Network is the two-feeder ring comprising Feeder 1 and Feeder 2.

As this is a Demand Connection, no CAF contribution is required.

The High-Cost Project Threshold (HCPT) applied is the Required Capacity x HCPT of £1,720 per kVA.

In this instance;

$70 \times £1,720 = £120,400$. The Customer will pay the costs in excess of £120,400 for works up to one voltage above the Point of Connection, therefore £363,000 (i.e, total Reinforcement cost - £120,400 = £242,600).

The Connection Charge for this Scheme is calculated as follows:

Reinforcement	Cost	Apportionment	Customer Contribution
Overlay 1200m of 11kV cable	£360,000	Total cost exceeding HCPT £363,000- £120,400	£242,600
11kV Jointing	£3,000		
Total Reinforcement Cost	£363,000		£242,600

Extension Assets	Cost	Apportionment	Customer Contribution
500m 11kV cable	£150,000	n/a	£150,000
500kVA substation	£70,000	n/a	£70,000
Termination of Customer's LV cable	£2,000	n/a	£2,000
LV Metering panel	£4,000	n/a	£4,000
11kV Jointing x2	£6,000	n/a	£6,000
Total Extension Asset Cost	£232,000		£232,000

Example 30: A new Generation Connection that has Reinforcement above the High-Cost Project Threshold.

A Customer wishes to connect a 225kVA wind farm (a Generation Connection).

In order to connect the wind farm the Minimum Scheme involves the installation of 590m of 11kV overhead line, 350m of 11kV cable and associated jointing and install switchgear into the substation. In addition, Reinforcement is required to replace the 33/11kV transformer to facilitate reverse power flow and the 11kV circuit breaker in the primary substation. The New Network Capacity following Reinforcement is 19,700 kVA. The total cost of the Reinforcement is £505,400.

The High-Cost Project Threshold (HCPT) applies to this connection. The HCPT is £200/kW and costs in excess of this threshold will be charged in full to the Customer.

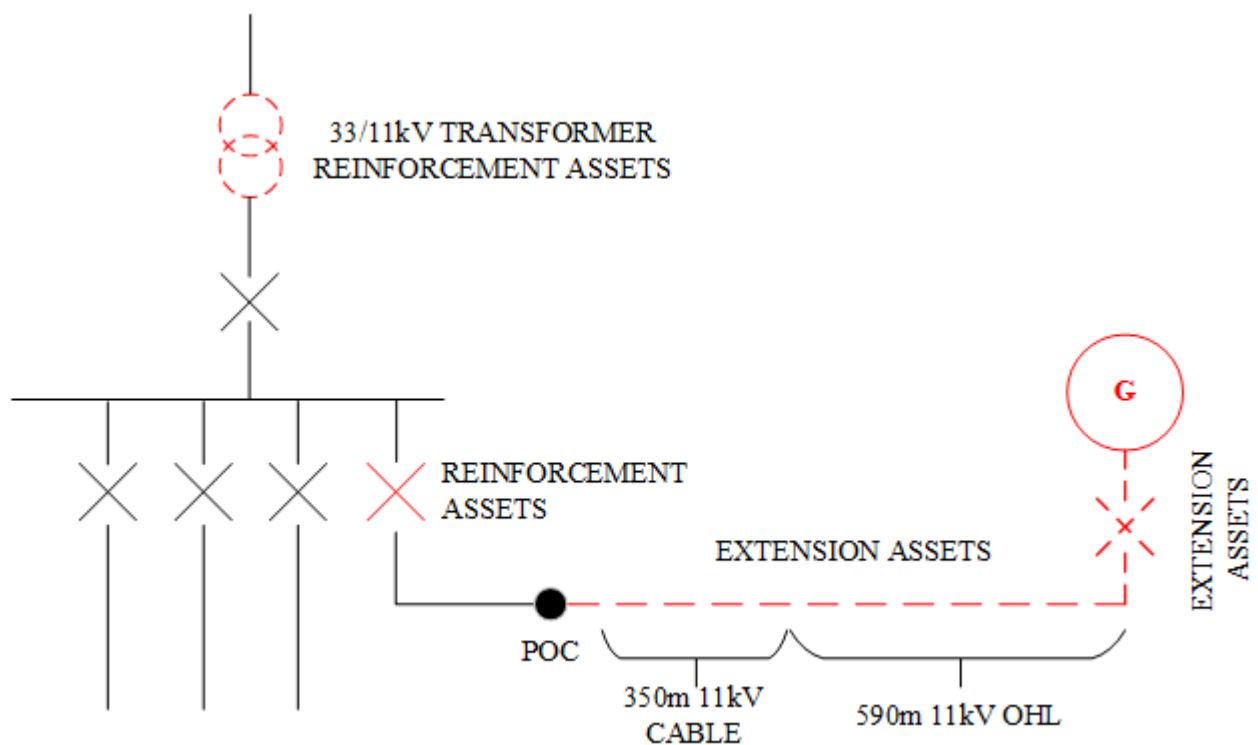

Reinforcement:

Security CAF calculation: the numerator in the CAF calculation is the Required Capacity of the Customer, i.e. 225kVA. The denominator is the New Network Capacity following Reinforcement, this being the maximum generation that could be connected whilst keeping the voltage rise within acceptable limits. This is 19,700kVA.

The High-Cost Project Threshold for Generation Connections is £200/kW.

The Reinforcement required to provide the connection is:

- 33/11kV transformer; and
- 11kV circuit breaker.

The 33/11kV transformer Reinforcement is one Voltage Level above the POC and not subject to the Security CAF. The work is covered by the High-Cost Project Threshold of £200/kW.

HCPT: $£200 \times 225 = £45,000$

$£505,400 - £45,000 = £460,400$ Customer Contribution

The 11kV circuit breaker Reinforcement of £30,000 is at the Voltage Level of the POC and is subject to the Security CAF. The work is under the High-Cost Project Threshold of £45,000 ($£200 \times 225$) and not covered.

Security CAF: $(225/19,700) \times 100 = 1.14\%$

$£30,000 \times 1.14\% = £342$ Customer Contribution

The Connection Charge for this Scheme is calculated as follows:

Reinforcement Over High-Cost Project Threshold	Cost	Apportionment	Customer Contribution
33/11kV Transformer Replacement	£475,400	£505,400- £45,000= £460,400	£460,400
11kV circuit breaker	£30,000		
Total Reinforcement Cost	£505,400		£460,400

Reinforcement Under High-Cost Project Threshold	Cost	Apportionment	Customer Contribution
HV circuit breaker	£30,000	$225/19,700 = 1.14\%$	£342
Total Reinforcement Cost	£30,000		£342

Extension Assets	Cost	Apportionment	Customer Contribution
Electrical substation works	£34,500	n/a	£34,500
Install 590m of 11kV Overhead Line	£53,500	n/a	£53,500
Install 350m of 11kV XLPE cable	£14,000	n/a	£14,000
Total Extension Asset Cost	£102,000		£102,000

Example 31: the Customer requirements for supply characteristics are greater than the Minimum Scheme.

A Customer with an existing single phase domestic connection with rated at 100 Amps (23 kVA) requests a three-phase connection to allow them to connect a three-phase load (e.g. a three-phase domestic welder). The property is located halfway along on a single phase 100m LV overhead line, which connects to a single phase 50kVA pole-top transformer feeding four properties. The pole-top transformer connects to the local Primary substation via a three-phase underground cable.

The existing network has sufficient capacity to accommodate the Required Capacity but the existing 50kVA pole-top transformer and 100m LV overhead line do not have a sufficient number of phases.

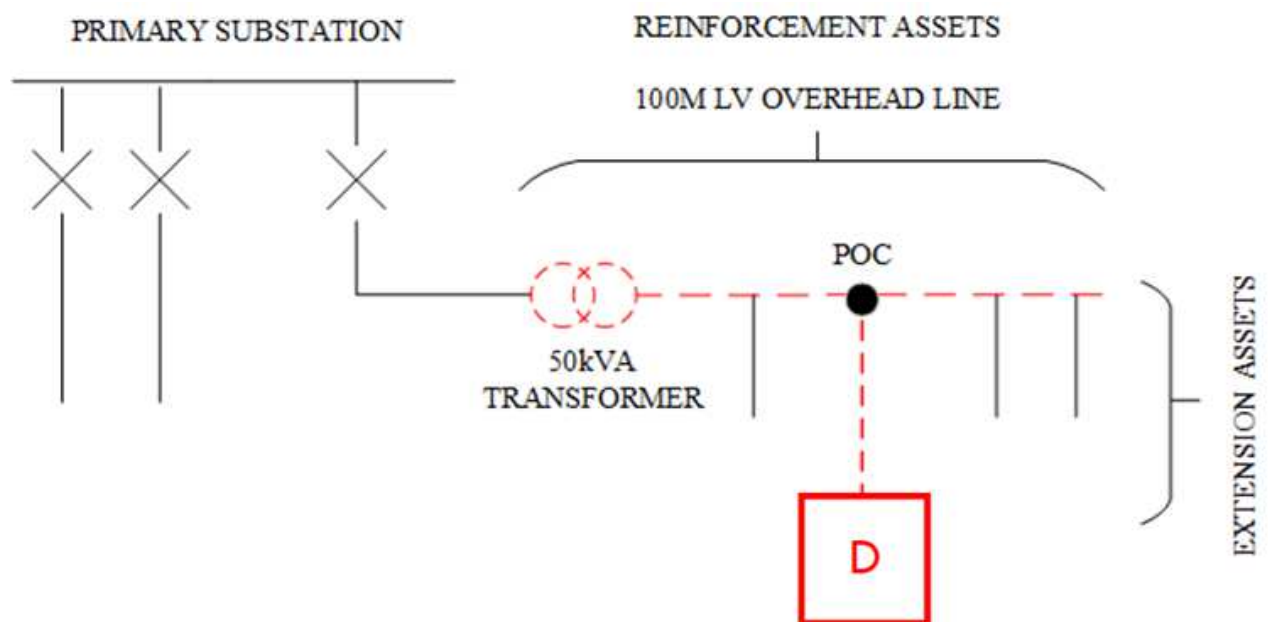

Reinforcement:

The Minimum Scheme is to replace the existing 100m LV overhead line in its entirety with a three-phase overhead line. The existing single phase 50kVA pole-top transformer will need to be replaced with a three-phase equivalent. The existing three-phase cable feed and the Primary substation are of sufficient capacity.

As the Reinforcement is only to accommodate the required number of phases, no cost apportionment will be applied.

The Connection Charge for this Scheme is calculated as follows:

Reinforcement	Cost	Apportionment	Customer Contribution
Replace existing single-phase LV Overhead Line with new 100m three-phase LV Overhead Line	£12,600	100%	£12,600
New three-phase 50kVA pole-top transformer	£20,000	100%	£20,000
LV Jointing	£300	100%	£300
Operation & Maintenance @32%* of £32,900	£10,528		£10,528
Total Reinforcement Cost (including O&M charge)	£43,428		£43,428

Extension Assets	Cost	Apportionment	Customer Contribution
New 30m three-phase 100A service	£1,600	n/a	£1,600
Single service breach joint	£300	n/a	£300
Total Extension Asset Cost	£1,900		£1,900

6 Our specific connection charging methodology

- 6.1 This section contains the elements of our Connection Charging Methodology which do not have analogous paragraphs in the Common Connection Charging Methodology. The methodology in this section will apply equally alongside the methodology in Section 4 of this document.

Capitalised Operation and Maintenance Charges

- 6.2 The Operation and Maintenance Percentage referred to in 4.16 is 24%.

Projects

- 6.3 Where we have reason to believe that an application for connection forms part of a larger project then we will use the aggregate capacity of the projects to determine the appropriate Connection Charge.

Non-Standard Substation Buildings

- 6.4 Where you require us to locate substation plant and equipment within a non-standard building or enclosure e.g., where the substation is to form an integral part of a building also to be used for other purposes then other charges will normally apply for building and design work and on-site inspections. Charges for this type of work will be consistent with those we make where we adopt networks from an ICP.

Charges for assessment and design

- 6.5 Where permitted under relevant legislation, charges for Assessment and Design may be applied. This may be by way of a standard charge based on the type, voltage, and maximum required capacity of the connection, as indicated in section 7C of this document. Where the applicant changes its requirements or requests multiple quotes in respect of the same or a similar connection to the premises, additional Assessment and Design work, not covered in the standard charge, may be required to update the original design. Where this is the case, the customer's charge in respect of Assessment and Design will be equal to the standard charge associated with the original Assessment and Design work, plus a charge in respect of the additional work applied by way of an hourly rate.

Reservation of Import Capacity

- 6.6 We may, on occasion, be required to pay charges for reserving capacity on another IDNO's network at the boundary between our network and theirs. On such occasions these charges will be passed through to you and will form part of the Connection Charge.
- 6.7 Any costs relating to the reservation of import capacity will be calculated in accordance with the upstream LDNO's own connection charging methodology and will be passed through to you as they are charged to us.
- 6.8 We will not make charges relating to the reservation of import capacity where the capacity being reserved relates directly to capacity available on our networks and an equivalent capacity charge has not been levied on us.

Contestable and Non-Contestable works

6.9 A list of the works that we deem to be contestable and the works that we deem to be non-contestable can be found in paragraphs 3.3-3.11.

7 Our connection charging statement

Introduction

- 7.1 This section sets out our Connection Charging Statement and is prepared in accordance with Standard Condition 14 of the Licence.
- 7.2 The purpose of this statement is to enable any person to make a reasonable estimate of the charges for which they may become liable for the provision of a connection to our Distribution System.
- 7.3 The minimum and maximum values of charges shown in the following tables are designed to provide you with an indication of the range of charges that would normally apply to a particular activity and are therefore not absolute limits on the minimum nor the maximum value of charge that may be levied. The actual charge for each activity will be calculated based upon the project specific circumstances which may take account factors that will influence the value of the charge payable to you.
- 7.4 All indicative charges in the table below are exclusive of VAT.
- 7.5 All indicative charges are applicable to connections to Distribution Systems owned by Advanced Electricity Networks Limited.
- 7.6 Connection Charges may contain some or all of the cost elements indicated in the following table. You do not need to have requested a Budget Estimate or Feasibility Study before you request a formal Connection Offer.

	Charge Element	Explanation
A	Budget Estimates	To identify the budget costs for connection to the existing Distribution System in advance of a formal application.
B	Feasibility Studies	To identify options for connection to the existing Distribution System in advance of a formal application.
C	Assessment and Design for all relevant work	To identify the most appropriate point on the existing Distribution System for connection of the Extension Assets, the design of the Extension Assets, any required Reinforcement and prepare the Connection Offer.
D	CIC Assessment and Design of the Non-Contestable Work	To identify the most appropriate point on the existing Distribution System for connection of the Extension Assets, the design of any required Reinforcement and prepare the Point of Connection Offer.
E	CIC Design Approval of the Contestable Work	For CIC, the approval of an Extension Assets design produced by an ICP.
F	Construction	Electric Lines and Electrical Plant forming part of the Extension. Assets and Reinforcement (both Contestable and Non-Contestable Assets).

G	CIC Final Works and Phased Energisation	<p>Final Works means the installation of the connection equipment in such a way that, subject to Energisation, the Premises are physically able to receive a supply of electricity from our Distribution System or (as the case may be) our Distribution System is physically able to receive a supply of electricity from the Premises.</p> <p>Phased Energisation, in relation to a part only of the Premises, means the physical ability, subject to the completion of Final Works, to allow an electrical current to flow from (or to) our Distribution System to (or from) that part by means of the insertion of a fuse or as a result of a switching operation.</p>
H	CIC Inspection and Monitoring	Inspection and Monitoring by us of the Contestable Work constructed by an ICP.
I	Land Rights	The costs of securing Land Rights in respect of Extension Assets and Reinforcement
J	Other	Other miscellaneous charges associated with the provision of the connection.

7.7 The following definitions are used in this section.

Single LV Service Demand Connection	an LV demand connection to single Premises, involving a single-phase connection and no significant work other than the provision of a service line and the electricity distributor's fuses.
Service Line	a low-voltage electric line or any part of that line that will, at the time it is provided, be used only for supplying single Premises, excluding any part of the line that, at the time it is provided, is intended by the distributor to be used to enable it to provide a connection to other Premises in respect of which the distributor has received, or would reasonably expect within the following 12 months to receive, a notice under section 16A(1) of the Act.

<p>Small Project Demand Connection</p>	<p>a connection (other than of a load that could reasonably be expected to cause disruption to other customers) (via low-voltage circuits fused at 100 amperes or less per phase with whole-current metering), and where the highest voltage of the assets involved in providing such connection, and any associated works, is low voltage, to:</p> <p>(a) a development Scheme requiring more than one but fewer than five single-phase connections at domestic Premises and involving only the provision of a service line and the electricity distributor's fuses; or</p> <p>(b) a development Scheme requiring fewer than five single-phase or two-phase connections at domestic Premises and involving an extension of the existing low voltage network; or</p> <p>a single Premises requiring a two-phase or three phase connection and involving only the provision of a service line and the electricity distributor's fuses.</p>
---	---

Quotation Accuracy Scheme

7.8 We are required in our Licence to submit from time to time to the Authority for approval a Quotation Accuracy Scheme (QAS). The QAS is intended to provide information so that you can assess whether the specific Connection Charge included with our Connection Offer to you is accurate in terms of consistency with our Connection Charging Statement.

7.9 The QAS only applies to Single LV Service Demand Connections and Small Project Demand Connections. The cost tables for these projects are given in tables F1 and F2.

7.10 The principles of the QAS are as follows:

- The QAS is not intended to be a mechanism for you to challenge the absolute cost of the Connection Charge.
- If the information included in the Connection Offer is such that the Connection Charge is outside the bands of indicative costs, then you would be eligible to challenge the accuracy of the Connection Offer. You would be required to provide a statement to explain why you believed the quotation to be outside the range.
- Absence of information in the Connection Offer does not in itself mean that the Connection Charge is inaccurate but does allow you to enter the QAS. This therefore acts as an incentive to us to include additional information to you to limit the number of customers eligible to enter to QAS.
- Where we review the Connection Offer and accept that we have not provided enough information and therefore the Connection Charge is outside the bands of indicative costs, the Connection Charge will be

deemed to be inaccurate, a penalty payment will be paid to you and a new Connection Offer issued. The revised Connection Charge may in fact be for the same value but with additional information provided.

- If we can demonstrate that additional information was provided in the Connection Offer in support of our Connection Charge, then no penalty payment will be made.
- Where we review the Connection Offer and accept that we have made an error, for example in estimating quantities then the Connection Charge will be deemed inaccurate. In these circumstances, a penalty payment will be paid, and a new Connection Offer issued.
- If we are able to provide additional information in support of our charges, then no payment would be made.
- The accuracy assessment will work both ways, i.e., any error may be an omission and a re-issued Connection Offer could be higher or lower than the original Connection Charge.
- Some tolerances for the error would apply, for example within 5% or £150 (whichever is greater). This prevents a disproportionate effect for assets such as small lengths of cable if our view and your view of the required length differ.
- The QAS is not intended to introduce standard charges for connections customers.
- The QAS will have specified time limited whereby you can challenge the Connection Charge but will not preclude you from accepting the Connection Charge.

7.11 Where you believe the Connection Offer provided by us is outside the “bandwidth” in the indicative charges table contained in this statement then you can enter the QAS.

7.12 You can enter the QAS by contacting us at the address given in Section 1.29.

PART A - Budget Estimates

7.13 If you are unable to make a formal Application because certain information that we require to make a Connection Offer is not available or if you are not in a position to progress to the construction phase, we can provide an indication of the charge for making the connection by means of a Budget Estimate (see paragraph 2.9 for further details). Our charges associated with the provision of Budget Estimates in advance of a formal Application are set out in the table below:

Category	Cost
Demand	
Single LV Service Demand Connection	£0
2 to 4 services single phase LV, no extension to LV network	£0
1-4 Premises, single phase LV, extension to the LV network required	£0
1 three phase LV service with whole current metering to a single Premises	£0
Other LV connection(s) with a total load up to 100kVA LV	£0
Other LV connection(s) with a total load greater than 100kVA and up to 250kVA LV not covered by the above	£0
Connection greater than 250kVA and up to 1MVA at LV	£0
Connection up to 250kVA at HV	£0
Connection greater than 250kVA and up to 1MVA at HV	£0
Connection greater than 1MVA and up to 3MVA at HV	£0
Connection greater than 3MVA and up to 10MVA at HV	£0
Connection greater than 3MVA and up to 10MVA at EHV	£0
Connection greater than 10MVA and up to 50MVA	£0
Connection greater than 50MVA	£0
Category	Cost

Generation	
Connection of a single Small-Scale Embedded Generator	£0
Connection of other generation at LV up to 20kVA not covered by the above	£0
Connection of other generation at LV greater than 20kVA and up to 50kVA	£0
Connection of other generation at LV greater than 50kVA	£0
Connection of generation at HV up to 250kVA	£0
Connection of generation at HV greater than 250kVA and up to 1MVA	£0
Connection of generation at HV greater than 1MVA	£0
Connection of generation at EHV up to 10MVA	£0
Connection of generation at EHV greater than 10MVA	£0
Connection of generation greater than 50MVA	£0

PART B - Feasibility Studies

- 7.14 Prior to making a formal Application for a Connection Offer you may request we undertake a Feasibility Study to establish the viability of making a connection to our Distribution System. We will carry out preliminary network analysis and provide an indicative connection assessment which will include the results of the network analysis and an outline of the engineering scheme to allow the connection. We will require payment in advance of the study being made and will notify you of the relevant study charges prior to commencing work.
- 7.15 Our charges associated with the provision of Feasibility Studies involving design in advance of a formal Connection Application are set out in the table below. Charges for any other activities, such as excavation works will be individually assessed and agreed with you before the work is undertaken. The Minimum Charge will always apply. Additional charges will only be applicable where the Applicant amends their connection requirements, and this necessitates us to carry out further analysis or assessment:

Category	Charge		Additional Charge	
	Min	Max	Min	Max
Single LV Service Demand Connection	POA	POA	POA	POA
2 to 4 services single phase LV, no extension to LV network	POA	POA	POA	POA
1-4 Premises, single phase LV, extension to the LV network required	POA	POA	POA	POA
1 three phase LV service with while current metering to a single Premises	POA	POA	POA	POA
Other LV connection(s) with a total load up to 100kVA	£230.00	£590.00	£40.00	£80.00
Other LV connection(s) with a total load greater than 100kVA and up to 250kVA not covered by the above	£280.00	£590.00	£40.00	£80.00
Connection greater than 250kVA and up to 1MVA at LV	£320.00	£590.00	£50.00	£80.00
Connection up to 250kVA at HV	£420.00	£590.00	£50.00	£80.00
Connection greater than 250kVA and up to 1MVA at HV	£420.00	£710.00	£50.00	£80.00
Connection greater than 1MVA and up to 3 MVA at HV	£420.00	£890.00	£50.00	£80.00
Connection greater than 3MVA and up to 10MVA at HV	£640.00	£1,420.00	£50.00	£80.00
Connection greater than 3MVA and up to 10 MVA at EHV	£1,190.00	£2,380.00	£80.00	£100.00

Category	Charge		Additional Charge	
	Min	Max	Demand	Min
Connection greater than 10MVA and up to 50MVA	£1,190.00	£3,870.00	£80.00	£100.00
Connection greater than 50MVA	£1,190.00	£7,750.00	£80.00	£100.00
Generation				
Connection of a single Small-Scale Embedded Generator	£140.00	£230.00	£70.00	£70.00
Connection of other generation at LV up to 20kVA not covered by the above	£190.00	£460.00	£40.00	£70.00
Connection of other generation at LV greater than 20kVA and up to 50kVA	£190.00	£610.00	£40.00	£70.00
Connection of other generation at LV greater than 50kVA	£350.00	£860.00	£50.00	£80.00
Connection of generation at HV up to 250kVA	£590.00	£980.00	£50.00	£80.00
Connection of generation at HV greater than 250kVA and up to 1MVA	£590.00	£1,230.00	£50.00	£80.00
Connection of generation at HV greater than 1MVA	£590.00	£2,500.00	£50.00	£80.00
Connection of generation at EHV up to 10MVA	£1,190.00	£3,930.00	£80.00	£100.00
Connection of generation at EHV greater than 10MVA	£1,190.00	£3,930.00	£80.00	£100.00
Connection of generation greater than 50MVA	£1,190.00	£7,750.00	£80.00	£100.00

Note 1: “LV”, “HV”, or “EHV” in the table above denotes the highest voltage of assets installed including any associated Reinforcement or diversionary works.

PART C - Assessment and Design for all relevant work

7.16 For applications received where you require us to undertake all the works, our charges associated with the identification of the most appropriate point on the existing Distribution System for connection and the design of any Extension Assets and/or Reinforcement are set out in the table below. We may levy additional assessment and design charges where the work undertaken exceeds the costs included in the minimum charge:

Category Demand	Charge		Additional Charge/hr	
	Min	Max	Min	Max
Single LV Service Demand Connection	£0.00	£120.00	n/a	n/a
2 to 4 services single phase LV, no extension to LV network	£0.00	£550.00	n/a	n/a
1-4 Premises, single phase LV, extension to the LV network required	£0.00	£550.00	n/a	n/a
1 three phase LV service with while current metering to a single Premises	£0.00	£120.00	n/a	n/a
Other LV connection(s) with a total load up to 100kVA	£0.00	£570.00	£0.00	£80.00
Other LV connection(s) with a total load greater than 100kVA and up to 250kVA not covered by the above	£0.00	£750.00	£0.00	£80.00
Connection greater than 250kVA and up to 1MVA at LV	£640.00	£2,770.00	£0.00	£80.00
Connection up to 250kVA at HV	£750.00	£1,490.00	£0.00	£80.00
Connection greater than 250kVA and up to 1MVA at HV	£750.00	£5,630.00	£0.00	£80.00
Connection greater than 1MVA and up to 3 MVA at HV	£960.00	£7,910.00	£0.00	£80.00
Connection greater than 3MVA and up to 10MVA at HV	£1,280.00	£9,180.00	£50.00	£100.00
Connection greater than 3MVA and up to 10 MVA at EHV	£9,180.00	POA	£80.00	£100.00
Connection greater than 10MVA and up to 50MVA	£8,940.00	POA	£80.00	£120.00
Connection greater than 50MVA	£8,940.00	POA	£80.00	£120.00

Category Generation	Charge		Additional Charge/hr	
	Min	Max	Min	Max
Connection of a single Small Scale Embedded Generator	£0.00	£140.00	£0.00	£80.00
Connection of other generation at LV up to 20kVA not covered by the above	£290.00	£690.00	£0.00	£80.00
Connection of other generation at LV greater than 20kVA and up to 50kVA	£590.00	£870.00	£0.00	£80.00
Connection of other generation at LV greater than 50kVA	£590.00	£1,350.00	£0.00	£80.00
Connection of generation at HV up to 250kVA	£1,280.00	£6,820.00	£0.00	£80.00
Connection of generation at HV greater than 250kVA and up to 1MVA	£1,420.00	£6,570.00	£0.00	£80.00
Connection of generation at HV greater than 1MVA	POA	£11,610.00	£0.00	£80.00
Connection of generation at EHV up to 10MVA	POA	£11,260.00	POA	£100.00
Connection of generation at EHV greater than 10MVA	POA	£11,260.00	POA	£100.00
Connection of generation greater than 50MVA	POA	£15,020.00	POA	£100.00

Note 1: “LV”, “HV”, or “EHV” in the table above denotes the highest voltage of assets installed including any associated Reinforcement or diversionary works.

PART D - CIC Assessment and Design of the Non-Contestable Work

7.17 For applications received where you have requested an ICP to carry out the Contestable Works, our charges associated with the identification of the most appropriate point on the existing Distribution System for connection of the Extension Assets and the design of any Network Reinforcement are set out in the Table below:

Category	Charge
Demand	
Single LV Service Demand Connection	£0
2 to 4 services single phase LV, no extension to LV network	£0
1-4 Premises, single phase LV, extension to the LV network required	£0
1 three phase LV service with while current metering to a single Premises	£0
Other LV connection(s) with a total load up to 100kVA	£0
Other LV connection(s) with a total load greater than 100kVA and up to 250kVA not covered by the above	£0
Connection greater than 250kVA and up to 1MVA at LV	£0
Connection up to 250kVA at HV	£0
Connection greater than 250kVA and up to 1MVA at HV	£0
Connection greater than 1MVA and up to 3 MVA at HV	£0
Connection greater than 3MVA and up to 10MVA at HV	£0
Connection greater than 3MVA and up to 10 MVA at EHV	£0
Connection greater than 10MVA and up to 50MVA	£0
Connection greater than 50MVA	£0

Category	Charge
Generation	
Connection of a single Small-Scale Embedded Generator	£0
Connection of other generation at LV up to 20kVA not covered by the above	£0
Connection of other generation at LV greater than 20kVA and up to 50kVA	£0
Connection of other generation at LV greater than 50kVA	£0
Connection of generation at HV up to 250kVA	£0
Connection of generation at HV greater than 250kVA and up to 1MVA	£0

PART E - CIC Design Approval of the Contestable Work

7.18 For applications received where you have elected an ICP to undertake the Contestable Work, our charges associated with the approval of an Extension Asset design produced by an ICP are set out in the Table below:

Category	Charge
Demand	
Single LV Service Demand Connection	£0
2 to 4 services single phase LV, no extension to LV network	£0
1-4 Premises, single phase LV, extension to the LV network required	£0
1 three phase LV service with whole current metering to a single Premises	£0
Other LV connection(s) with a total load up to 100kVA LV	£0

Category	Charge
Other LV connection(s) with a total load greater than 100kVA and up to 250kVA LV not covered by the above	£0
Connection greater than 250kVA and up to 1MVA at LV	£0
Connection up to 250kVA at HV	£0
Connection greater than 250kVA and up to 1MVA at HV	£0
Connection greater than 1MVA and up to 3MVA at HV	£0
Connection greater than 3MVA and up to 10MVA at HV	£0
Connection greater than 3MVA and up to 10MVA at EHV	£0
Connection greater than 10MVA and up to 50MVA	£0
Connection greater than 50MVA	£0
Generation	
Connection of a single Small-Scale Embedded Generator	£0
Connection of other generation at LV up to 20kVA not covered by the above	£0
Connection of other generation at LV greater than 20kVA and up to 50kVA	£0
Connection of other generation at LV greater than 50kVA	£0
Connection of generation at HV up to 250kVA	£0
Connection of generation at HV greater than 250kVA and up to 1MVA	£0
Connection of generation at HV greater than 1MVA	£0

Category	Charge
Connection of generation at EHV up to 10MVA	£0
Connection of generation at EHV greater than 10MVA	£0
Connection of generation greater than 50MVA	£0

PART F - CONSTRUCTION

F1 Small Services covered by the Quotation Accuracy Scheme

- 7.19 Our charges associated with the construction of small services (1-4 single phase connections or a single three phase connection up to 60kVA) are set out in the table below.
- 7.20 Charges will cover both the Contestable Work and Non-Contestable Work; however, these will be identified separately on your Connection Offer. Note that your Connection Offer will also include charges for Assessment and Design as outlined in paragraph 7.16 and may include other charges.
- 7.21 The charges in the table below are inclusive of liaison with highway authorities, sending street works notices and signing, lighting, and guarding. These charges exclude traffic management costs e.g., temporary traffic lights, road closures etc. and Traffic Management Act costs. Where these additional charges are relevant, these will be included in your connection charge.
- 7.22 These Charges exclude charges for any easement, wayleaves or land transfers that are required, and these are detailed in Table I, Land Rights.
- 7.23 These charges are covered by the Quotation Accuracy Scheme outlined under paragraphs 7.8-7.12 of this section.

Activity	Description	Factors	Unit	Min	Max
Single phase service	Single phase service, from a passing main, including cable, mains service joint hole, (excavate to site boundary), and termination. Service cable length up to 5 metres. Duct within site boundary installed by third party	Same side service in typical tarmac footpath	1	£1,400.90	£2,102.00
		Same side service in typical grass verge	1	£767.70	£1,156.50
		Cross road service in typical carriageway	1	£2,032.40	£3,048.70
	Additional metres of service cable	In typical tarmac footpath	m	£161.30	£242.00
		In typical grass verge	m	£31.40	£47.60
		In typical carriageway	m	£200.50	£300.40
	Duct laid by us		m	£8.30	£13.10

Activity	Description	Factors	Unit	Min	Max
Three phase service (60kVA)	Single phase service, from a passing main, including cable, mains service joint hole, (Excavate to site boundary), and termination. Service cable length up to 5 metres. Duct within site boundary installed by third party	Same side service in typical tarmac footpath	1	£1,507.30	£2,260.60
		Same side service in typical grass verge	1	£1,251.60	£1,877.80
		Cross road service in typical carriageway	1	£2,138.60	£3,208.50
	Additional metres of service cable	In typical tarmac footpath	m	£105.00	£157.30
		In typical grass verge	m	£53.80	£81.00
		In typical carriageway	m	£222.90	£333.80
	Duct laid by us		m	£8.30	£13.10
Three Phase Service (60kVA)	Low voltage mains cable. Excavate 10m of ground and install LV mains cable and reinstate to match existing surface, includes straight joint onto main and bottle end	Trench or duct by others (including backfill and reinstatement)	1	£953.80	£1,430.70
		In typical tarmac footpath	1	£2,911.30	£4,367.40
		In typical grass verge	1	£2,002.50	£3,003.40
		In typical carriageway	1	£3,693.00	£5,539.40
	Additional metres of LV mains cable	Trench or duct by others (including backfill and reinstatement)	m	£23.80	£35.70
		In typical tarmac footpath	m	£114.40	£171.60
		In typical grass verge	m	£63.20	£95.30
		In typical carriageway	m	£232.30	£348.10
	Duct laid by us		M	£8.30	£13.10

F2 Service Alterations

- 7.24 Our charges associate with changes to the service positions for single services (single phase connection or three phase connections up to 60kVA) are set out in the table below.
- 7.25 The charges in the table below are inclusive of liaison with highway authorities, sending street works notices and signing, lighting, and guarding. These charges exclude traffic management costs e.g., temporary traffic lights, road closures etc. and Traffic Management Act costs. Where these additional charges are relevant, these will be included in your connection charge.
- 7.26 These charges exclude charges for any easement, wayleaves or land transfers that are required, and these are detailed in Table I, Land Rights.
- 7.27 These charges are subject to the Quotation Accuracy Scheme outlined under paragraphs 7.8-7.12 of this Section.

Activity	Description	Factors	Unit	Min	Max
Single phase service alteration	(Excavate to site boundary), and termination. Service cable length up to 5 metres. Duct within site boundary installed by third party	Service alteration in customer land	1	£1,549.80	£2,325.00
		Same side service alteration in typical grass verge including excavation, backfill and reinstatement to site boundary and joint hole	1	£1,135.10	£1,702.60
		Same side service alteration in typical tarmac footpath including excavation, backfill and reinstatement to site boundary and joint hole	1	£1,549.80	£2,325.00
		Cross road service alteration in typical carriageway including excavation, backfill and reinstatement to the site boundary and joint hole	1	£2,181.20	£3,271.60

Activity	Description	Factors	Unit	Min	Max
Single phase service alteration	Additional metres of service cable	Customers Land	m	£22.40	£33.30
		In typical grass verge (including excavation, installation, backfilling, and reinstatement)	m	£53.80	£81.00
		In typical tarmac footpath (including excavation, installation, backfilling and reinstatement)	m	£105.00	£157.30
		In typical carriageway (including excavation, installation, backfilling and reinstatement)	m	£222.90	£333.80
Three phase service alteration (60kVA)	Three phase service including service cable, joint and termination. Service cable length up to 5 metres, duct installed by third party	Service alteration in customer land	1	£1,698.10	£2,546.70
		Same side service alteration in typical grass verge including excavation, backfill and reinstatement to site boundary and joint hole	1	£1,400.70	£2,100.80
		Same side service alteration in typical tarmac footpath including excavation, backfill and reinstatement to site boundary and joint hole	1	£1,656.40	£2,484.70
		Cross road service alteration in typical carriageway including excavation, backfill and reinstatement to the site boundary and joint hole	1	£2,287.80	£3,431.40
	Additional metres of service cable	Customers Land	m	£53.80	£81.00
		In typical grass verge (including excavation, installation, backfilling, and reinstatement)	m	£53.80	£81.00
		In typical tarmac footpath (including excavation, installation, backfilling and reinstatement)	m	£105.00	£157.30
		In typical carriageway (including excavation, installation, backfilling and reinstatement)	m	£222.90	£333.80

F3 Other Services not covered by the QAS.

- 7.28 Our charges associated with construction of services to the Entry/Exit Point that are not covered by the Quotation Accuracy Scheme are given in the table below. These charges are for the connection of service cable only.
- 7.29 Charges below cover both the Contestable Work and Non-Contestable Work; however, these will be identified separately on your Connection Offer or Point of Connection Offer. Note that your Connection Offer will also include charges for Assessment and Design.

7.30 The charges in the table below are inclusive of liaison with highway authorities, sending street works notices and signing, lighting, and guarding. These charges exclude Traffic Management Act costs. Where these are additional charges that are relevant, these will be included in you Connection Charge.

7.31 These charges exclude charges for any easement, wayleaves or land transfers that are required, and these are detailed in Table I, Land Rights.

Activity	Description	Unit	Min	Max
Single phase service, up to 100A (20kVA)	One single phase service, from a passing or extended main, including service cable, mains service joint, and termination. Service cable length up to 5 metres per service. Duct installation, excavation and backfill joint hole undertaken by third party	1	£579.80	£869.70
	Multiple single-phase service, from an extended main, including service cable. Mains service joints and termination. Service cable length up to 5 metres per service. Duct installation, excavation and backfill joint hole undertaken by third party	1	POA	POA
	Excavation and backfill of joint hole	1	£632.60	£948.90
	Additional metres of service cable	m	£15.90	£23.90
Three phase service up to 100A per phase (60kVA)	A single three phase service, from a passing main, including service cable, mains service joint, and termination. Service cable length up to 5 metres per service. Duct installation, excavation and backfill joint hole undertaken by third party	1	£865.00	£1,297.50
	Excavation and backfill of joint hole	1	£843.00	£1,264.50
	Additional metres of three phase service cable	m	£20.50	£30.80
Three phase service up to 200A per phase (120kVA)	A single three phase service, from a passing main, including service cable, mains service joint, and termination. Service cable length up to 5 metres per service. Duct installation, excavation and backfill joint hole undertaken by third party	1	£1,970.30	£2,955.50
	Excavation and backfill of joint hole	1	£843.00	£1,264.50
	Additional metres of three phase service cable	m	£20.50	£30.80
Three phase service up to 300A per phase (180kVA)	A single three phase service, from a passing main, including service cable, mains service joint, and termination. Service cable length up to 5 metres per service. Duct installation, excavation and backfill joint hole undertaken by third party	1	£1,292.60	£3,226.70
	Excavation and backfill of joint hole	1	£843.00	£1,264.50
	Additional metres of three phase service cable	m	£20.50	£30.80

Activity	Description	Unit	Min	Max
Three phase service up to 300A per phase (240kVA)	A single three phase service, from a passing main, including service cable, mains service joint, and termination. Service cable length up to 5 metres per service. Duct installation, excavation and backfill joint hole undertaken by third party	1	£2,151.10	£3,226.70
	Excavation and backfill of joint hole	1	£843.00	£1,264.50
	Additional metres of three phase service cable	m	£20.50	£30.80
Three phase service over 240kVA	A single three phase service, from a passing main, including service cable, mains service joint, and termination. Service cable length up to 5 metres per service. Duct installation, excavation and backfill joint hole undertaken by third party	1	£2,119.00	£3,178.60
	Excavation and backfill of joint hole	1	£843.00	£1,264.50
	Additional metres of three phase service cable	m	£20.50	£30.80
Services to Multi occupied Premises	Installation of a multi-way cut-out up to 10 ways from a passing or extended main, including cables for adjacent communal metering, mains service join, and termination. Service cable length up to 5 metres per service. Duct installation, excavation and backfill joint hole undertaken by third party	1	£1,616.60	£2,424.90
	Installation of a multi-way cut-out of greater than 10 ways from a passing or extended main, including cables for adjacent communal metering, mains service join, and termination. Service cable length up to 5 metres per service. Duct installation, excavation and backfill joint hole undertaken by third party	1	£3,310.40	£4,965.60
	Installation of rising mains and laterals excluding civils and containment work	1	POA	POA
	Excavation and backfill of joint hole	1	£843.00	£1,264.50
	Additional metres of three phase service cable	m	£20.50	£30.80

F4 Unmetered Supplies

7.32 Our Charges associated with construction activities in respect of unmetered supplies.

7.33 Charges below cover both the Contestable and Non-Contestable Work; however, these will be identified separately on your Connection Offer or Point of Connection Offer. Note that your Connection Offer may also include charges for Assessment and Design as outlined in paragraph 7.16 and may include other charges.

7.34 The charges in the table below are inclusive of liaison with highway authorities, sending street works notices and signing, lighting, and guarding. These charges exclude Traffic Management Act costs. Where these charges are relevant, these will be included in your Connection Charge.

7.35 These charges exclude charges for any easement, wayleave or land transfers that are required, and these are detailed in Table I, Land Rights.

Activity	Description	Unit	Min	Max
Unmetered Supplies	New connection up to 5 metres excluding excavation and reinstatement	1	£293.80	£440.80
	Disconnection excluding excavation and reinstatement	1	£127.60	£191.50
	Transfer or reconnection up to 5 metres excluding excavation and reinstatement	1	£127.60	£191.50
	Additional metres of service cable including excavation and reinstatement	m	£22.40	£33.60
Unmetered Supplies	New connection on same side of road including excavation and reinstatement	1	£1,549.80	£2,324.80
	New connection up to 10 metres on other side of road including excavation and reinstatement	1	£3,142.10	£4,713.20
	Disconnection excluding excavation and reinstatement	1	£127.60	£191.50
	Transfer or reconnection up to 5 metres including excavation and reinstatement	1	£1,549.80	£2,324.80
	Additional metres of service cable including excavation and reinstatement	m	£222.90	£334.40
Unmetered Supplies	Rent-a-Jointer team (excluding materials)	Per day	POA	POA
Unmetered Supplies	Administrative charge for ICP work	Per lamp	POA	POA

F5 Mains Cables

- 7.36 Our charges associated with cables are set out in the table below:
- 7.37 Charges below cover both the Contestable and Non-Contestable Work; however, these will be identified separately on your Connection Offer or Point of Connection Offer. Note that your Connection Offer will also include other charges for Assessment and Design as outlined in paragraph 7.16 and may include other charges.
- 7.38 The charges in the table below are inclusive of liaison with highway authorities, sending street works notices and signing, lighting, and guarding. These charges exclude traffic management e.g., temporary traffic lights, road closures etc. and Traffic Management Act costs. Where these additional charges are relevant, these will be included in your connection charge.
- 7.39 These charges exclude charges for any easement, wayleaves, or land transfers that are required, and these are detailed in Table I, Land Rights.
- 7.40 Where the cable charges are associated with the connection there may be an additional charge for the Final Connection to our existing Distribution System and these charges are identified in 7.45.

Activity	Description	Unit	Min	Max
Extension of LV mains cable of 95mm ² or less	Lay 10m cable or less including jointing onto existing main in prepared trench or pulling through duct installed by others. All backfill and reinstatement by others	1	£595.30	£893.00
	Additional metres of mains cable	m	£26.70	£40.10
	Lay 10m cable or less in typical footpath or carriageway, including excavation and reinstate to match the existing surface	1	£1,093.70	£1,640.50
	Additional metres of mains cable	m	£26.70	£40.10
	Lay 10m cable or less in unmade ground, including excavation and reinstate to match the existing service	1	£582.40	£873.60
	Additional metres of mains cable	m	£26.70	£40.10

Activity	Description	Unit	Min	Max
Extension of LV mains cable of between 95mm ² and 185mm ²	Lay 10m cable or less including jointing onto existing main in prepared trench or pulling through duct installed by others. All backfill and reinstatement by others	1	£747.10	£1,120.70
	Additional metres of mains cable	m	£35.90	£53.90
	Lay 10m cable or less in typical footpath or carriageway, including excavation and reinstate to match the existing surface	1	£1,185.50	£1,778.20
	Additional metres of mains cable	m	£35.90	£53.90
	Lay 10m cable or less in unmade ground, including excavation and reinstate to match the existing service	1	£674.20	£1,011.30
	Additional metres of mains cable	m	£35.90	£53.90
Extension of LV mains cable of greater than 185mm ²	Lay 10m cable or less including jointing onto existing main in prepared trench or pulling through duct installed by others. All backfill and reinstatement by others	1	£4,516.80	£6,775.20
	Additional metres of mains cable	m	£40.70	£61.00
	Lay 10m cable or less in typical footpath or carriageway, including excavation and reinstate to match the existing surface	1	£1,233.20	£1,849.80
	Additional metres of mains cable	m	£40.70	£61.00
	Lay 10m cable or less in unmade ground, including excavation and reinstate to match the existing service	1	£721.90	£1,082.90
	Additional metres of mains cable	m	£40.70	£61.00

Activity	Description	Unit	Min	Max
Extension of HV mains cable	Lay 20 metres cable or less in prepared trench by pulling through duct installed by others. All backfills and reinstatement by others including jointing onto existing main	1	£1,135.50	£1,703.30
	Additional metres of mains cable	m	£56.70	£85.10
	Lay 20m cable or less in typical footpath or carriageway, including excavation and reinstate to match the existing surface	1	£2,916.30	£4,374.50
	Additional metres of mains cable	m	£56.70	£85.10
	Lay 20m cable or less in unmade ground, including excavation and reinstate to match the existing surface	1	£1,707.80	£2,561.70
	Additional metres of mains cable	m	£56.70	£85.10
Extension of 33kV mains cable	Lay 30m cable or less in prepared trench or pulling through duct installed by others. All backfill reinstatement by others including jointing onto existing main	1	POA	POA
	Additional metres of mains cable	m	POA	POA
	Lay 30m cable or less in typical footpath or carriageway, including excavation and reinstate to match the existing surface	1	POA	POA
	Additional metres of mains cable	m	POA	POA
	Lay 30m cable or less in unmade ground, including excavation and reinstate to match the existing surface	1	POA	POA
	Additional metres of mains cable	m	POA	POA

Activity	Description	Unit	Min	Max
Extension of 66kV mains cable	Lay 30m cable or less in prepared trench or pulling through duct installed by others. All backfill and reinstatement by others including jointing onto existing main	1	POA	POA
	Additional metres of mains cable	m	POA	POA
	Lay 30m cable or less in typical footpath or carriageway, including excavation and reinstate to match the existing surface	1	POA	POA
	Additional metres of mains cable	M	POA	POA
Extension of 132kV mains cable	Lay 40m cable or less in prepared trench or pulling through duct installed by others. All backfill and reinstatement by others including jointing onto existing main	1	POA	POA
	Additional metres of mains cable	m	POA	POA
	Lay 40m cable or less in typical footpath or carriageway, including excavation and reinstate to match the existing surface	1	POA	POA
	Additional metres of mains cable	m	POA	POA
	Lay 40m cable or less in unmade ground, including excavation and reinstate to match the existing surface	1	POA	POA
	Additional metres of mains cable	M	POA	POA

F6 Substations

- 7.41 Our charges associated with substations are set out in the table below.
- 7.42 Charges below cover both the Contestable and Non-Contestable Work; however, these will be identified separately on your Connection Offer or Point of Connection Offer. Note that your Connection Offer will also include charges for Assessment and Design as outlined in paragraph 7.16 and may include other charges.
- 7.43 The charges in the table below are inclusive of liaison with highway authorities, sending street works notices and signing, lighting, and guarding. These charges exclude Traffic Management Act costs. Where these additional charges are relevant, these will be included in your connection charge.
- 7.44 These charges exclude charges for any easement, wayleaves or land transfers that are required, and these are detailed in Table I, Land Rights.

Activity	Description	Unit	Min	Max
HV/LV substation ground mounted transformer	Install ground mounted transformer up to and including 315kVA including RMU and LV fuse board or circuit breaker.	1	£43,693.30	POA
	Install ground mounted transformer greater than 315kVA and up to and including 500kVA, including RMU and LV fuse board/cabinet or circuit breaker.	1	£47,270.20	POA
	Install ground mounted transformer greater than 500kVA and up to and including 800kVA, including RMU and LV fuse board/cabinet or circuit breaker.	1	£89,001.00	POA
	Install ground mounted transformer greater than 800kVA and up to 1000kVA including RMU and LV fuse board/cabinet or circuit breaker.	1	£89,001.00	POA
	Install ground mounted transformer greater than 1000kVA, including RMU and LV fuse board/cabinet or circuit breaker	1	POA	POA
	Transformer change.	1	POA	POA
HV only substation (customer owned HV/LV transformer)	Install an internal HV switchgear (e.g., RMU) and metered circuit breaker	1	POA	POA
	Install an external HV switchgear (e.g., RMU) and metered circuit breaker	1	POA	POA

Activity	Description	Unit	Min	Max
EHV/HV primary substation	New indoor single transformer substation	1	POA	POA
	New indoor double transformer substation	1	POA	POA
	New outdoor single transformer substation	1	POA	POA
	New outdoor double transformer substation	1	POA	POA
	Add an additional transformer at existing indoor substation	1	POA	POA
	Add an additional transformer at existing outdoor substation	1	POA	POA
	Change transformer	1	POA	POA
	Change HV switchgear	1	POA	POA
132kV/EHV substation	New indoor single transformer substation	1	POA	POA
	New indoor double transformer substation	1	POA	POA
	New outdoor single transformer substation	1	POA	POA
	New outdoor double transformer substation	1	POA	POA
	Add an additional transformer at existing indoor substation	1	POA	POA
	Add an additional transformer at existing outdoor substation	1	POA	POA
	Change transformer	1	POA	POA
	Change HV switchgear	1	POA	POA

PART G CIC Final Works and Energisation

- 7.45 The table below sets out the charges for the final connections to our network.
- 7.46 The charges below cover non-Contestable work or where we are asked to under-take live jointing on Contestable Assets and will be identified separately on your Connection Offer. Note that your Connection Offer will also include charges for Assessment and Design as outlined in paragraph 7.16 and may include other charges.
- 7.47 These charges exclude charges for any easement, wayleaves or land transfers that are required, and these are detailed in Table I, Land Rights.
- 7.48 The charges below are exclusive of all cable laying or substation installation costs and all joint hole excavation and reinstatement. These will have been covered by separate charges or have been carried out by your ICP.

Activity	Description	Unit	Cost
Service Connections	Low voltage service joint to all sizes of low voltage main inclusive of service polarity and earth loop impedance test at the service position.	1	POA
LV Mains Energisation	Low voltage mains Energisation of all sizes by mains joint to an existing cable of any size.	1	POA
	Low voltage bottle end to mains cable, any size.	1	POA
	Low voltage mains Energisation of all sizes by terminating to an existing piece of low voltage switchgear, including all associated operating costs.	1	POA
	Low voltage mains Energisation of all sizes by a connection to an overhead line.	1	POA
HV Mains Energisation	High voltage cable Energisation of all sizes by a joint to an existing cable of any size including all associated operational costs.	1	POA
	High voltage cable Energisation of all sizes by connection to existing overhead line including all associated operational costs.	1	POA
	High voltage cable Energisation of all sizes by termination to an existing piece of switchgear including all associated operational costs.	1	POA

Activity	Description	Unit	Cost
Operational Work	LV operation work including identification of cables requiring LV operations only.	1	POA
	LV commissioning work including switching to commission LV assets installed by ICPs.	1	POA
	HV operational work including for identification of cables requiring HV operations.	1	POA
	HV commissioning work including all operational work required to isolate network and commission HV assets installed and jointed by ICPs.	1	POA

PART H CIC Inspections and Monitoring of Contestable Works

7.49 Our charges associated with site visits to inspect and monitor the construction of the Extension Asset by ICPs are set out in the table below.

Category	Unit	Charge
LV Network	per site visit	POA
HV Network	per site visit	POA
EHV Network	per site visit	POA
132kV Network	per site visit	POA
HV/LV Substation	per site visit	POA
EHV/HV Substation	per site visit	POA
HV/LV Civils	per site visit	POA
EHV/HV Civils	per site visit	POA

PART I - Land Rights

7.50 Our charges associated with Land rights are set out in the table below. These charges exclude the cost of any compensation or consideration payable to third parties.

Category	Min	Max
Residential Development substation site from developer (Including easements from developer)	£750	POA
Commercial/industrial development substation from developer (Including easements from developer)	£750	POA
Residential /commercial/industrial development substation site from third party owner(s) (including easements from same third-party owner(s))	£750	POA
Wayleave(s)/easement(s) only on a residential site from Developer	£750	POA
Wayleave(s)/easement(s) only on a commercial/industrial site from Developer	£750	POA
Wayleave(s)/easement(s) from third party owner(s)	£750	POA

PART J Other

7.51 Our miscellaneous charges associated with the provision of the connection are set out in the table below.

Category	Charge
Negotiation of special terms	POA
Meetings not covered by other charges	POA
Abortive Visit	POA
Planning approval	POA
Traffic management costs e.g., temporary traffic lights, road closures, etc.	POA

8 Glossary of terms

Act	The Electricity Act 1989 (as amended).
Adoption Agreement	Is the agreement for us to adopt the Contestable Work, subject to the satisfaction of certain conditions.
Affected Parties	Are all customers whose Connection Offer(s)/ Point of Connection Offer(s) have been identified by us as being interactive.
Application Date	Is the date upon which we have received all the information we require in respect of an application. A list of the information required can be found at paragraph 2.7
Bilateral Connection Agreement	An agreement between us and another LDNO setting out the terms and conditions under which an embedded network shall be entitled to be and remain connected to the Distribution System.
Budget Estimate	Is an indication of the charge for providing a connection to our Distribution System. This will not include detailed design work and will be a result of preliminary assessment only. A Budget Estimate does not constitute a formal Connection Offer and the price may differ considerably between any Budget Estimate and a formal Connection Offer
Building Network Operator (BNO)	Is the operator of a private wires network within a building or buildings.
Business Day	Any day other than a Saturday, a Sunday, Christmas Day, Good Friday, or a day which is a bank holiday within the meaning of the Banking and Financial Dealings Act 1971 and will be from 9:00am to 5:00pm (GMT or BST as applicable).

<p>Committed Network</p>	<p>Means assets that are not yet installed and commissioned on our Distribution System, but which are planned to be so as a result of other Connection Offer(s)/ Point of Connection Offer(s) which have been made by us and accepted by other applicant(s).</p>
<p>Common Connection Charging Methodology</p>	<p>Means the Connection Charging Methodology set out in Schedule 22 of the DCUSA, as amended from time to time, and the required by all Distribution Services Providers to form part of their Connection Charging Methodology.</p>
<p>Competition in Connections (CIC)</p>	<p>Is the term attributed to the opening up of the market for the design, procurement, and installation of new assets necessary to accommodate a new or modified electricity connection.</p>
<p>CIC Charges</p>	<p>Are the charges detailed in parts D, E, G, H, I, and J of Section 7.</p>
<p>Connection Agreement</p>	<p>Is an agreement between you and us which sets out the terms you will be, and remain, connected to our Distribution System.</p>
<p>Connection Charge</p>	<p>The payment to be made by the applicant to us for the provision of the connection.</p>
<p>Connection Offer</p>	<p>Is our formal written offer to you to provide a connection to our Distribution System.</p>
<p>Contestable Work</p>	<p>Is work that may be carried on, or in connection to, our Distribution System by an accredited ICP. A list of work considered to be contestable can be located at paragraph 3.3.</p>
<p>CUSC</p>	<p>The Connection and Use of System Code which constitutes the contractual framework for connection to, and use of, the GB Transmission System</p>

Customer	The person requesting the connection.
DCUSA	The Distribution Connection and Use of System Agreement designated as such by the Authority under condition 22 of the Licence.
De-energise	To deliberately prevent the flow of electricity to or from an Exit/Entry Point for any purpose other than a system outage on us Distribution System (and cognate expressions shall be construed accordingly).
Demand Connection	A connection which is not a Generation Connection
Development Phase	The three-year period, unless otherwise agreed with us, commencing on the date of Energisation of an embedded network over which the development is constructed.
Disconnect	Means to permanently De-energise an Exit/ Entry Point by the removal of all or part of our equipment (and cognate expressions shall be construed accordingly).
Distributed Generation Connections Guide	The guide produced by us as required by our Licence which provides guidance on the connection process for distributed generation.
Distribution Code	Is a code that covers material technical aspects relating to the connection to, and operation of, our Distribution System in place in accordance with Section 21 of our licence.
Distribution Services Area	Shall have the meaning given to it in the Licence.

Distribution Services Provider	Shall have the meaning given to it in the Licence.
Distribution System	The system (as defined in the Licence) consisting of (wholly or mainly) of electric lines owned or operated by us and used for the distribution of electricity. Electricity meters and meter boxes do not form part of our Distribution System.
ECCR	The Electricity (Connection Charges) Regulations 2002 (SI 2002/93) as amended from time to time or the Electricity (Connection Charges) Regulations 2017 (SI 2017/106) as amended from time to time, as applicable.
ECCR Prescribed Period	The relevant period from the date on which a connection is made as prescribed by the ECCR, being either (a) five years, for connections made prior to 6 April 2017: or (b) ten years, for connections made on or after 6 April 2017
EHV	More than 22kV but not more than 72kV.
Electric Lines	<p>Means any line which is used for carrying electricity to or from an Exit/Entry Point and includes unless the context otherwise requires:</p> <ul style="list-style-type: none"> any support for such line, which is to say, any structure, pole, or other thing in, on, by or from which any such line is or may be supported, carried, or suspended. any apparatus connected to such line for the purpose of carrying electricity; and any wire, cable, tube, pipe, or other similar thing (including its casing or coating) which surrounds or supports, or is surrounded or supported by, or is installed in close proximity to, or is supported, carried or suspended in association with, any such line
Electric Plant	Means any plant, equipment, apparatus, or appliance used for or for purposes connected with the distribution of electricity.

	(Including any metering equipment) other than an Electric Line.
Electricity Storage	is the conversation of electrical energy into a form of energy which can be stored, the storing of that energy, and the subsequent reconversion of that energy back into electrical energy.
Electricity Generation	is the process of generating electricity
Energise	To deliberately allow the flow of electricity to or from an Exit/ Entry Point where such a flow of electricity has never previously existed (and cognate expressions shall be construed accordingly).
Enhanced Scheme	Is a scheme which has been designed to include one of more of the following. Additional assets not required as part of the minimum scheme. Assets of a larger capacity than required by the Minimum Scheme. Assets of a different specification than required by the Minimum Scheme.
Entry/ Exit Point	A point at which electricity, whether metered or unmetered, enter or exit our Distribution System.
Existing Capacity	is, for existing customers; a) the Maximum Capacity used in the calculation of their use of system charges; or b) for customers who are not charged for use of system on the basis of their Maximum Capacity the lower of. i. No. of phases x nominal phase neutral voltage (kV) x fuse rating (A); and ii. The rating of the service equipment.
Existing Network	Means our currently installed and commissioned Distribution System.

Extension Assets	Are assets installed to connect a party or parties to the existing distribution network, but which exclude Reinforcement assets.
Fault Level	The maximum prospective current or power that will flow into a short circuit at a point on the network, usually expressed in MVA or kVA.
Fault Level Contribution from Connection	Is the assessment of the fault level contribution from the equipment to be connected taking account of its impact at the appropriate point on the Distribution System. Where an existing Customer requests a change to a connection then the Fault Level Contribution from Connection is defined as the incremental increase in Fault Level caused by the Customer.
Feasibility Study	Is a study to consider a number of different options for providing your connection and will provide estimated costs for each option as appropriate. A Feasibility Study will not constitute a formal connection offer.
Flexible Connections	are connection arrangements whereby a Customer's export or import of electricity is managed (often through real-time control) based upon contracted and agreed principles of available capacity. Flexible Connections typically allow quicker and cheaper connection to the Distribution System but are made on the basis that there is no limit on the extent to which a user's access can be interrupted.
Full Planning Permission	an approval in writing by the relevant planning authority of all of the details of a proposed development such that the proposed development may proceed in accordance with that approval.
GB Transmission System	The system consisting of (wholly or mainly) of high voltage electric wires owned or operated by transmission licensees within Great Britain.
Generation connection	means a connection to a Premises where the primary purpose of the Premises is wholly or mainly Electricity Generation and/or Electricity Storage. In determining such primary purpose we will consider: <ul style="list-style-type: none"> i. if the Maximum Capacity of the connection of the Premises to the Distribution System for export is greater than the Maximum Capacity for import; ii. if the Premises has a Generation Licence; iii. if the Premises has a Generation Licence Exemption;

	and/or iv. any other information we consider relevant.
Generation License	means the owner or occupier of the Premises holds a licence to carry out the activity specified in section 4(1)(a) of the Act.
Generation License Exemption	means the owner or occupier of the Premises has an exemption from holding a Generation Licence, including under the Electricity (Class Exemptions from the Requirement for a Licence) Order 2001.
Guaranteed Standards of Performance	Standards of service backed by a guarantee and set out in the Electricity (Standards of Performance) Regulations 2005 (as amended).
High-Cost Project Threshold	is defined in paragraph 4.20
HV	More than 1kV but not more than 22kV.
Independent Connections Provider (ICP)	A person/team with sufficient accreditation to carry out all or part of the Contestable Work.
Interactive Connection Applications	Arise when we receive two or more applications for a connection which could individually make use of the same part of the Distribution System, but where there is insufficient spare capacity or other network constraints on our Distribution System that will prevent both/all being connected.
Interactive Connection Offers	Are Connection Offers / Point of Connection Offers made in respect of Interactive Connection Applications.
Interactive Queue	Is the queue into which Affected Parties' interactive Connection Applications will be placed according to the Application Date

<p>Interruptions Incentive Scheme</p>	<p>The scheme which provides incentives on us to deliver a good level of performance in respect of customer interruptions and customer minutes lost.</p>
<p>Land Rights</p>	<p>All such rights in, under or over Land as are necessary for the construction, installation, operation, repair, maintenance, renewal or use of the Contestable Work or Non-Contestable Work.</p>
<p>Licence Exempt System</p>	<p>Is a distribution system operated by a person or persons who has been granted an exemption (including class exemptions) from the requirement to hold a distribution licence by the Secretary of State</p>
<p>Licensed Distribution Network Operator (LDNO)</p>	<p>The holder of a Licence to distribute electricity.</p>
<p>LV</p>	<p>Not more than 1kV.</p>
<p>Maximum Capacity</p>	<p>Means in relation to any connection the maximum amount of electricity, as agreed with us and expressed in kW or kVA, which can be imported from or exported onto our Distribution System.</p>
<p>Meter Point Administration Number (MPAN)</p>	<p>Is a 21-digit reference to uniquely identify Exit/ Entry Point, such as individual domestic residences.</p>
<p>Minimum Scheme</p>	<p>Is the Scheme with the lowest overall capital cost (as estimated by us), solely to provide the Required Capacity. The Minimum Scheme is subject to engineering policy and standards as described in 4.3</p>
<p>National Electricity Registration Scheme</p>	<p>Is a national registration system for accrediting ICPs to enable them to carry out contestable work.</p>

New Network Capacity	is defined in Section 4
NETSO	means the national electricity transmission system operator for Great Britain from time to time.
NGET	National Grid Electricity Transmission plc.
Non-Contestable Work	Is work on, or in relation to a connection to, our distribution system that cannot be undertaken by an ICP and must be carried out by us or our appointed agents. A list of non-Contestable work can be found in Section 3.7-3.8.
Non-Curtailable Connection	means a connection which is not a Curtailable Connection.
Notice of Interactivity	Is a notice provided by us, in writing, that your connection application is interactive with another application that we have received. The validity period of any current Connection Offer will be reduced to thirty days from the date of the notification where more than thirty days were still outstanding.
Outline Planning Permission	a decision in writing by the relevant planning authority on the general principles of how a site can be developed, which is subject to subsequent approval of one or more reserved matters.
Point of Connection Offer	Is the offer that we make to you to carry out the non-Contestable work only to allow connection to our Distribution System which will, if accepted by you, create a legally binding contract between you and us.
Point of Connection (POC)	Is the point (or points) of physical connection to our existing Distribution System.

Premises	Means any land, building or structure
Reinforcement	Is defined as assets that add capacity (network or fault level) to the existing shared use Distribution System.
Relevant Section of Network	<p>Is the part or parts of the Distribution System which require(s) Reinforcement. Normally this will comprise:</p> <p>the existing assets, at the voltage level that is being reinforced, that would have been used to supply you (so far as they have not been replaced) has sufficient capacity been available to connect you without reinforcement; and/or the new assets, at the same voltage level, that are to be provided by way of Reinforcement.</p> <p>Where it is unclear what assets would have supplied the Customer in the event that sufficient capacity had been available, the existing individual assets with the closest rating to the new assets will be used. There may be more than one RSN.</p>
Rent-a-Jointer Services	The service relating to hiring of resource from us to facilitate the provision of unmetered connections.
Required Capacity	Is the Maximum Capacity agreed with the Customer. In the case of multiples connections (e.g., a housing development) it may be adjusted after consideration of the effects of diversity. Where an existing Customer requests an increase in capacity then it is the increase above their Existing Capacity
Scheme	Our network design to provide the connection
Service Line	A low-voltage electric line or any part of that line that will, at time it is provided, be used only for supplying single premises, excluding any part of the line that, at the time it is provided, is intended by the distributor to be used to enable it to provide a connection to other premises in respect of which the distributor has received, or would reasonable expect within the following 12 months to receive, a notice under section 16A(1) of the Act.

Single LV Service Demand Connection	<p>Is an LV demand connection to single Premises, involving a single phase connection and no significant work other than the provision of a service line and the electricity distributor's fuses.</p>
Small Project Demand Connection	<p>Is a connection (other than a load that could be reasonably expected to cause disruption to other customers, via low-voltage circuits fused at 100 amperes or less per phase with whole current metering), and where the highest voltage of the assets involved in providing such connection and any associated works, is low voltage, to:</p> <ul style="list-style-type: none"> a) a development scheme requiring more than one but fewer than five single-phase connections at domestic premises and involving only the provision of a service line and the electricity distributor's fuses; or b) a development scheme requiring fewer than five single-phase or two-phase connections at domestic premises and involving an extension of the existing low voltage network; or c) a single premise requiring a two-phase or three-phase connection and involving only the provision of a service line and the electricity distributor's fuses.
Speculative Developments	<p>Are developments which have one or more of the characteristics set out in 4.54.</p>
SSEG (Small Scale Embedded Generation)	<p>Is a source of electrical energy rated up to and including 16 Amperes per phase, single or multi-phase, LV and designed to operate in parallel with our Distribution System.</p>
Supplier	<p>A person who holds a Supply Licence.</p>
Supply Licence	<p>A licence granted under section 6(1)(d) of the Act.</p>

<p>Supply Number</p>	<p>A unique identifier of those Entry/Exit Points on the Distribution System which are used for the purposes of either taking a supply of electricity or for the connection of a distributed generator, and which forms the basis of the metering point record on the Company's registration system.</p>
<p>Validity Period</p>	<p>The period for which a connection Offer or Point of Connection Offer is open for acceptance.</p>
<p>Voltage of Connection</p>	<p>Is the voltage at the Point of Connection between the existing distribution network and the assets used to provide the connection. For clarity, this is not necessarily the voltage of supply to the Customer.</p>
<p>Working Day</p>	<p>Any day other than a Saturday, a Sunday, Christmas Day, Good Friday, or a day which is a bank holiday within the meaning of the Banking and Financial Dealings Act 1971.</p>